

品质、创新、高效、诚信
Quality, Innovation, High-Efficiency, Credit

Vertrieb in der EU:
www.belluna.eu

SIKELAN

面向世界开拓国际化市场
Facing the world developing the market

R134a

R600a

R404A

R290

浙江麦迪制冷科技股份有限公司
ZHEJIANG MAIDI REFRIGERATION TECHNOLOGY CO.,LTD.

地址：中国杭州余杭区良渚街道大陆工业园经二路
ADD: Jinger Road Dalu Industrial Park, Liangzhu Street, Yuhang District, Hangzhou, China.
电话/TEL: 0086-571-8874 6383/8874 6477/88746499
传真/FAX: 0086-571-8875 9800/8875 9810
邮箱EMAIL: sikelan@sikelan.com
网址/WEB: www.sikelan.com



2020年3月 印

品质、创新、高效、诚信
Quality, Innovation, High-Efficiency, Credit



股票代码(STOCK CODE): 835011
ISO9001/ISO14001/OHSMS18000

SIKELAN®

商用、家用压缩机
Commercial and Domestic Compressors



R134a R600a R404A R290

浙江麦迪制冷科技股份有限公司
ZHEJIANG MAIDI REFRIGERATION TECHNOLOGY CO.,LTD.



COMPANY DIRECTORY

公司目录

设备和技术展示	EQUIPMENT AND TECHNOLOGY DISPLAY	1
销售网络	SALES NETWORK	3
款型明细介绍	THE DETAILS OF THE MODELS	5
压缩机型号命名说明	COMPRESSOR MODELS IDENTIFICATION AND DESIGNATION	8
工作范围	RANGE OF APPLICATION	9
丙烷制冷剂和制冷系统的应用	APPLICATION OF PROPANE REFRIGERANT AND REFRIGERATION SYSTEM	11
直流压缩机安装说明	DC COMPRESSOR INSTRUCTION	13
数字温控器	DIGITAL THERMOSTAT	17
直流压缩机	DC COMPRESSOR	21
压缩机技术资料	COMPRESSOR TECHNICAL DATA	23
压缩机外型尺寸	COMPRESSOR DIMENSIONS	51
安装图, 接线图, 底脚图	COMPRESSOR MOUNTING, ELECTRICAL WIRING DIAGRAM, MOUNTING BRACKET	53
包装数据	PACKING DATA	56
产品通用要求和执行标准	GENERAL REQUIREMENTS & EXECUTIVE STANDARDS	57

浙江麦迪制冷科技股份有限公司，创立于2002年，是一家正在蓬勃发展中的高新企业，专业研发制造全封闭和半封闭压缩机与机组，以及干燥过滤器、气液分离器、油分离器等制冷管路配件。

公司座落于有“中国天堂”美誉的浙江省杭州市。环境幽雅，交通便利，距上海港、宁波港均为2.5小时车程，距离杭州萧山国际机场45分钟车程。

公司建有办公楼及标准厂房40000平方米。技术力量雄厚，拥有自己的研究、开发、制造、检测中心，并引进国际先进高新设备。公司通过ISO9001、ISO14001、OHS18001国际管理体系认证，质量达到国内外先进水平，产品通过UL、ETL、CE、CB、CCC等认证。产品畅销全国三十多个省市，并大量出口到欧洲、美洲、澳洲、中东、非洲及东南亚各国。高品质、高性价比及优质的服务，受到广大客商的一致好评。

公司经营宗旨：市场为导向、质量求生存、科技求发展、管理争效益、服务为信誉。

公司经营理念：品质、创新、高效、诚信。

公司自主品牌：斯柯兰

Zhejiang MAIDI Refrigeration Technology Co., Ltd, It is a flourishing High-Tech enterprise which was founded in 2002. We specialize in developing and manufacturing the hermetical and semi-hermetic compressors & units, and all kinds of refrigeration parts such as the Filter Drier, Liquid Accumulator and Oil Separator.

We are located in Hangzhou City, Zhejiang Province, who has the reputation of China Heaven. With quiet surrounding advantageous geographical location and convenient transportation, It will take 2.5 hours to Shanghai or Ningbo port, and 45 minutes to Hangzhou Xiaoshan International Airport by car.

Our company owns the standard plant and office building which covering 40000M2. With abundant technique force, we have our own researching, developing, manufacturing, inspecting and testing centers, and imported the international advanced high-tech equipments. Our company has passed the ISO9001, ISO14001, OHS18001 international management system certificates. The products have got UL, ETL, CE, CB, and CCC certificates. Our products are not only selling strongly in more than 30 provinces and municipality, but also largely exporting to Europe, America, Australia, Middle East, Africa and South Asia. We have won an excellent reputation from the customers and friends by our product quality, price versus performance ratio and service.

Company Management Principle: Marketing for Guideline, Quality for Existence, Technology for Development.

Management for Efficiency, Service for Credibility.

Company Business concept: Quality, Innovation, High-Efficiency, Credit.

Company Proprietary Brand: SIKELAN

EQUIPMENT AND TECHNOLOGY DISPLAY
设备与技术展示



检测中心



可靠性测试台



气缸螺钉预紧



螺钉自动穿簧



机器人自动注油



机器人焊接



机芯自动入壳



曲轴精磨



机器人弯管



电泳漆设备

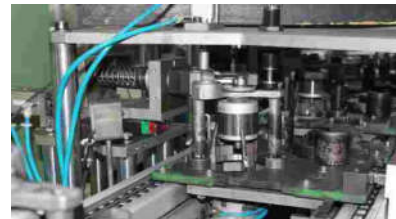

活塞顶隙自动测量



压缩机商检



抽真空线



压缩机人漆



连杆自动螺钉机



电机螺钉预紧

SALES NETWORK

销售网络

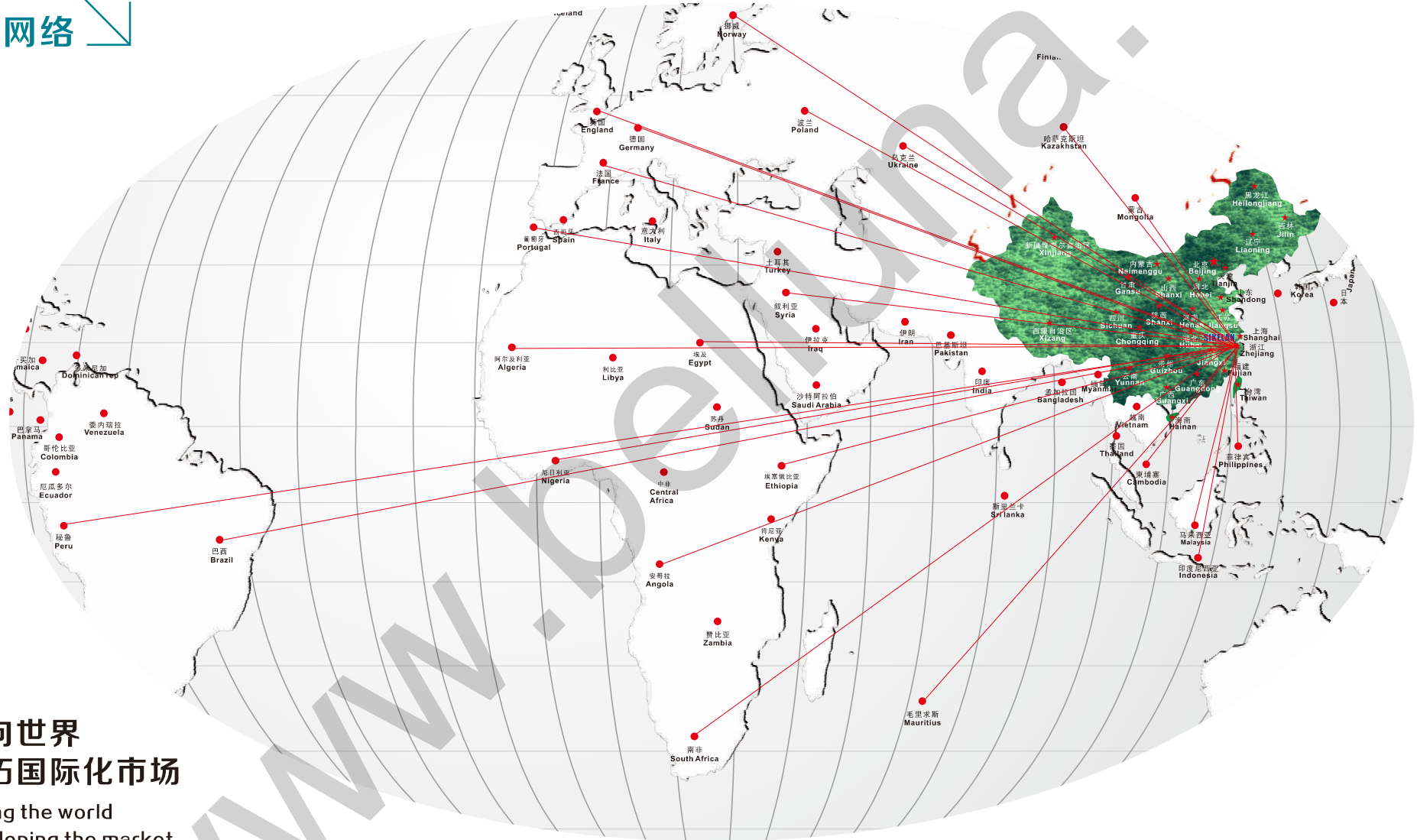

面向世界
开拓国际化市场

Facing the world
developing the market

THE DETAILS OF THE MODELS

款型明细介绍



DC 系列

适用机型:
以移动设备中的冷藏柜为主, 例如船艇、汽车、卡车、带篷货车、客车

应用范围:
低背压、中背压、高背压

可用电压:
12/24V DC, 48V可定制

制冷剂:
R134a, R600a

DC range

Suitable machines:
In mobile applications, e.g. cooling boxes, boats, caravans, trucks, vans, buses, etc

Applications:
LBP, M/HBP

Available voltage:
12/24V DC, 48V can be customized

Refrigerants:
R134a, R600a



MX range

Suitable machines:
Ice maker, Dehumidifier, Beers coolers, Merchandisers

Applications:
LBP, M/HBP

Available voltage:
220-240V/50-60Hz

Refrigerants:
R134a, R600a, R290, R404A

ML 系列

适用机型:
制冰机、啤酒柜、陈列柜

应用范围:
低背压、中背压、高背压

可用电压:
220-240V/50-60Hz
110-120V/50-60Hz

制冷剂:
R134a, R600a,

ML range

Suitable machines:
Ice maker, Beers coolers, Merchandisers

Applications:
LBP, M/HBP

Available voltage:
220-240V/50-60Hz
110-120V/50-60Hz

Refrigerants:
R134a, R600a,

MX 系列

适用机型:
制冰机、除湿机、啤酒柜、陈列柜

应用范围:
低背压、中背压、高背压

可用电压:
220-240V/50-60Hz

制冷剂:
R134a, R600a, R290, R404A



MQ 系列

适用机型:
制冰机、啤酒柜、陈列柜

应用范围:
低背压、中背压、高背压

可用电压:
220-240V/50-60Hz
110-120V/50-60Hz

制冷剂:
R134a, R600a

MQ range

Suitable machines:
Ice maker, Beers, coolers, Merchandisers

Applications:
LBP, M/HBP

Available voltage:
220-240V/50-60Hz
110-120V/50-60Hz

Refrigerants:
R134a, R600a

L range

Suitable machines:
Water dispensers, mini Bottlecoolers, befrigerators, Refrigerators, Freezers

Applications:
LBP, M/HBP

Available voltage:
220-240V/50-60Hz
110-120V/50-60Hz

Refrigerants:
R134a, R600a, R290

L 系列

适用机型:
饮水机、迷你饮料/啤酒柜、冰箱、冷柜

应用范围:
低背压、中背压、高背压

可用电压:
220-240V/50-60Hz
110-120V/50-60Hz

制冷剂:
R134a, R600a, R290



COMPRESSOR MODELS IDENTIFICATION AND DESIGNATION 压缩机型号命名说明

MD range

Suitable machines:
Refrigerated islands, Kitchen freezers

Applications:
LBP, M/HBP

Available voltage:
220-240V/50-60Hz
110-120V/50-60Hz

Refrigerants:
R134a, R290, R404A

MD 系列

适用机型:
商超岛柜、厨房冷柜

应用范围:
低背压、中背压、高背压

可用电压:
220-240V/50-60Hz
110-120V/50-60Hz

制冷剂:
R134a, R290, R404A

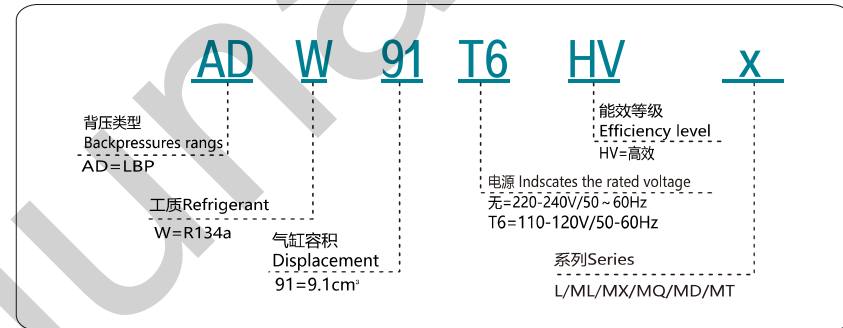

VFC range

Suitable machines:
Refrigerated islands, Kitchen freezers

Applications:
LBP, MBP

Available voltage:
220-240V/50-60Hz

Refrigerants:
R134a, R600a

VFC 系列

适用机型:
冷柜、冰箱

应用范围:
低背压、中背压

可用电压:
220-240V/50-60Hz

制冷剂:
R134a, R600a

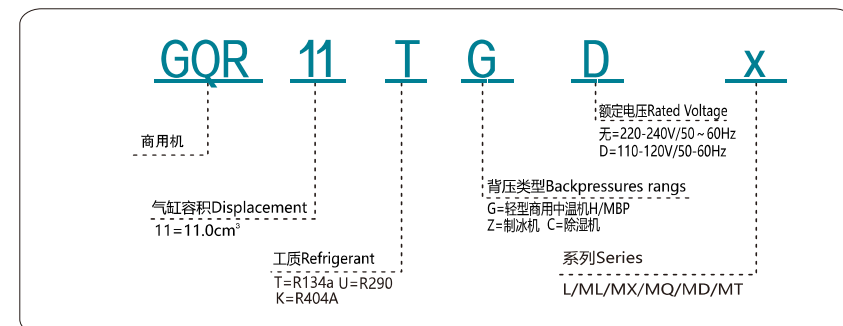
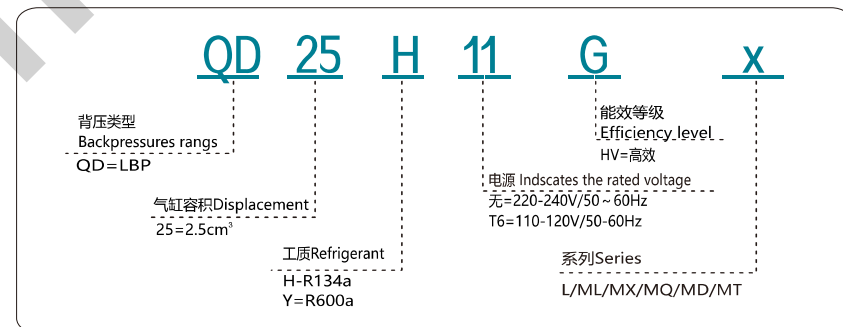

RANGE OF APPLICATION 工作范围

环温Ambient temperature: 43℃

回气温度Return temperature: 32.2℃

环温Ambient temperature: 32℃

回气温度Return temperature: 20℃

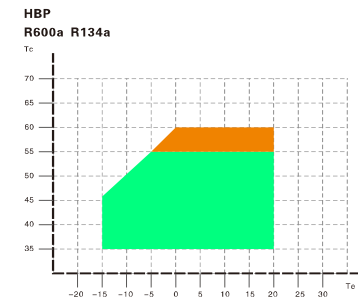
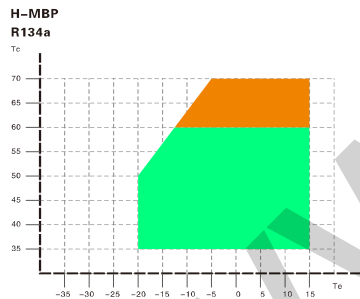
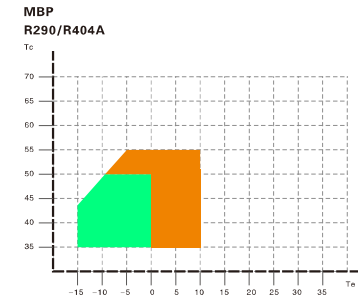
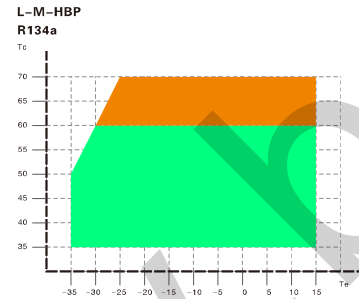
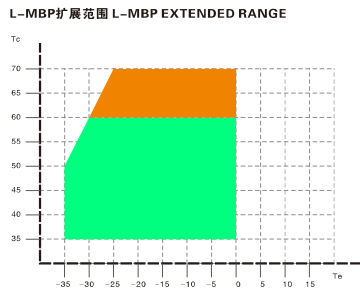
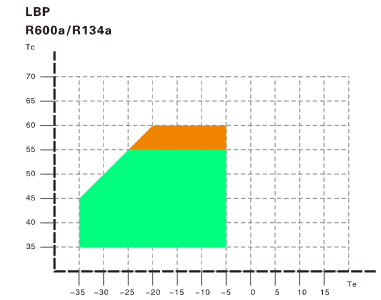
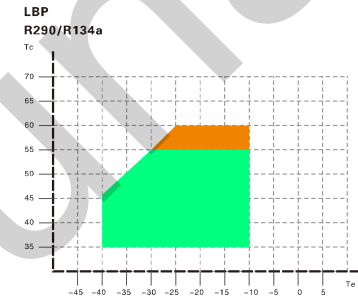
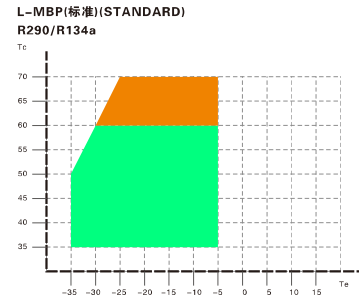
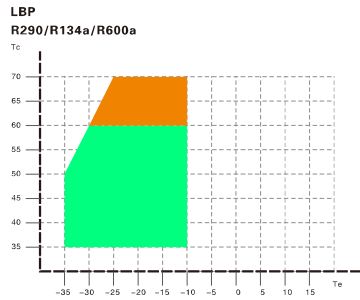

运行工况 Operation Condition
极限工况 Transient Condition

运行工况 Operation Condition
极限工况 Transient Condition

APPLICATION OF PROPANE REFRIGERANT AND REFRIGERATION SYSTEM 丙烷制冷剂 and 制冷系统的应用

R134a单位容积制冷量是R290的一半，在相同制冷量条件下，R290压缩机的排量约为R134a的60%，R290制冷剂充注量较R134a可减少40%~50%。

The unit refrigerating capacity of R134a is half of R290. Under the same cooling capacity, R290 compressor displacement is about 60% of R134a compressor, and the charge of R290 refrigerant can be reduced by 40% to 50% compared with R134a.

R134a切换至R290 Replace R134a with R290	R134a	LBP	R290	LBP
电源 (POWER)	型号 (MODEL)	ASHRAE(W)	型号 (MODEL)	ASHRAE(W)
220V 50Hz	QD35HG	75	GQR30U	80
	ADW86	200	GQR45U	208
	ADW91	225	GQR55U	230
	ADW110	240	GQR60U	280
	ADW128	320	GQR70U	320
	ADW142	350	GQR80U	360
	ADW153	380	GQR90U	400
	ADW168	410	GQR90U	400
			GQR11U	500
			GQR12U	550
		GQR14U	650	
		GQR16U	740	
		GQR19U	790	

R134a切换至R290 Replace R134a with R290	R134a	HBP	R290	HBP
电源 (POWER)	型号 (MODEL)	ASHRAE(W)	型号 (MODEL)	ASHRAE(W)
220V 50Hz	GQR35TG	385	GQR30U G	420
	GQR55TG	525	GQR45U G	540
	GQR60TG	665	GQR55U G	680
	GQR80TG	880	GQR60U G	840
	GQR90TG	990	GQR70U G	1000
	GQR11TG	1180	GQR80U G	1150
	GQR12TG	1300	GQR90U G	1280

R404A单位容积制冷量与R290相当，在相同制冷量条件下，可选择排同等量或偏大的R290压缩机，R290制冷剂充注量较R404A可减少40%~50%。

The unit refrigerating capacity of R404A is equivalent to R290. Under the same cooling capacity, you can choose the same or larger displacement of R290 compressor. The charge of R290 refrigerant can be reduced by 40% to 50% compared to R404A.

R404A切换至R290 Replace R404A with R290	R404A	LBP	R290	LBP
电源 (POWER)	型号 (MODEL)	ASHRAE(W)	型号 (MODEL)	ASHRAE(W)
220V 50Hz	GQR45K	244	GQR55U	230
	GQR55K	305	GQR70U	320
	GQR60K	365	GQR80U	360
	GQR70K	395	GQR90U	400
	GQR80K	465	GQR11U	500
	GQR90K	515	GQR11U	500
	GQR11K	565	GQR12U	550
	GQR12K	640	GQR14U	650
	GQR14K	750	GQR16U	740
	GQR16K	850	GQR19U	790

一、Precautions for using of Propane R290

1. Equipped with flammable gas detection and alarm device
 - 1.1 The detector shall be set in the areas where there may be a large cargo leakage, such as the storage area, filling area, sealing area and the vent of repair area
 - 1.2 Calibrate combustible gas detector regularly (at least once a year)
 - 1.3 When the concentration of combustible gas exceeds the standard, alarm output of corresponding level shall be provided, for example, when the alarm closing value is 20% LEL, the alarm indicator light is on, the exhaust fan accelerates operation, and the power switch of valve light shall be cut off; when the alarm closing value is 40% LEL, the alarm indicator light is on, and the alarm sound shall be given, and all power supply shall be cut off except boiler static system and exhaust system.
 - 1.4 The exhaust system shall be relatively independent with automatic and manual control. When the exhaust system is not started, the relevant equipment cannot be started; when the exhaust system fails, the relevant power supply will be cut off.
 - 1.5 Detection and alarm devices shall be operated 24 hours a day.

2. Eliminate sources of ignition

- 2.1 In the danger zone, it is necessary to strictly monitor all possible mechanical frictional heat and chemical reaction heat. The temperature of any part must not exceed 200 °C. Pay special attention to sparks and heat caused by electrical short circuits and disconnections. Direct heating by electric heating equipment is prohibited.
- 2.2 Electric control cabinet, alarm cabinet, lighting, fan and other facilities shall have explosion-proof grade, and control cabinet, junction box, electrical connector, etc. shall be sealed reliably.

3. Anti-static

- 3.1 Propane cylinder, grab pump, filling machine, repair and recovery machine, exhaust device and equipment frame shall be of metal structure, the middle of non-metal connecting hose shall be wrapped with metal framework, and both ends of the metal framework shall be grounded.
- 3.2 Propane pipelines should have as few turns as possible, and especially avoid sharp turns.
- 3.3 Personnel working in hazardous areas shall wear anti-static clothing, anti-static shoes, and soles shall be beaten with iron

4. Lightning protection

- 4.1 When propane storage warehouse cannot be protected by lightning arrester in workshop, independent lightning rod shall be set.
- 4.2 When the outdoor air outlet of combustible gas cannot be protected by the lightning rod or wire in the workshop, the lightning rod or wire shall be set additionally, and its grounding wire can be connected with the grounding electrode in the workshop.

5. Ground connection

- 5.1 The propane storage area shall be equipped with special anti-static grounding electrode, and the propane cylinder shall be firmly grounded.

6. Warning Sign

- 6.1 The site of the propane production line should have obvious safety production signs, the site should have obvious signs of "dangerous areas", and the propane storage and transportation equipment should comply with GB7231.
- 6.2 There shall be clear identification for maintenance in hazardous area and operation in open fire area

7. Perfusion

- 7.1 Sufficient fire-fighting equipment shall be set up, and obvious warning signs shall be provided.
- 7.2 The filling equipment shall meet the national explosion-proof electrical standards and have explosion-proof certificate.

8. Personnel training

- 8.1 Operators shall be trained in propane safety knowledge to understand the basic characteristics and safety requirements of propane.
- 8.2 Operators should wear labor protection supplies when they are on duty. The dress should meet the requirements of anti-static. It is not allowed to change clothes and use static electricity or sparks in the work area.
- 8.3 Irrelevant personnel should not enter the propane working area. When non-regional personnel enter the operation area, they shall follow the safety regulations of the operation area.
- 8.4 Operators should be proficient in emergency handling methods.

9. Emergency measure

- 9.1 When personnel inhale propane, they shall leave the site and go to the fresh air place quickly to keep breathing unobstructed. If breathing is difficult, they shall be given oxygen. If breathing stops, they shall be given artificial respiration immediately and get medical treatment as soon as possible.
- 9.2 When people inhaling propane, gargle with water and give milk or egg white quickly. Seek medical treatment as soon as possible.
- 9.3 When propane enters the eye, lift the eyelid, wash with flowing water or normal saline for at least 15 minutes, and seek medical treatment as soon as possible.
- 9.4 When the skin is in contact with propane, remove the contaminated clothes, wash the skin thoroughly with soap water and clear water for at least 15 minutes, and seek medical treatment as soon as possible.

二、Design of propane refrigeration system R134a becomes R290

1. Compressor, in the MBP application, when the refrigeration capacity is the same, it can be replaced by R290 compressor with smaller displacement, generally 60% of the displacement of R134a compressor.
2. Condenser, at the same condensing temperature, such as 45 °C, the thermal conductivity of the liquid refrigerant in the condenser is higher, 17% higher than that of R134a, which can appropriately reduce the size of the condenser. In addition, since the power consumed by R290 compressor per unit cooling capacity is lower, 12% lower than R134a, the heat exchanged by the theoretical condenser is equal to the cooling capacity plus the power consumed by the compressor, so a slightly smaller condenser can meet the required cooling capacity.
3. Evaporator, at the same evaporation temperature, for example -10 °C, the thermal conductivity of gas and liquid in the evaporator is higher than R134a, so the evaporator size can be slightly smaller.
4. Capillary tube, under the same cooling capacity, the capillary size is longer, theoretically about 2.9 times of R134a.
5. Charge volume, since the density of R290 is smaller, when the size of evaporator and condenser is unchanged, that is, under the same volume condition, the charging amount is 40%~50% of R134a.

三、Design of propane refrigeration system R404a becomes R290

1. Compressor, in LBP applications, when the cooling capacity is the same, it can be replaced with the same displacement or slightly larger R290 compressor.
2. Condenser, at the same condensing temperature, such as 45 °C, the thermal conductivity of the liquid refrigerant in the condenser is higher, 3% lower than R404A, so a slightly smaller condenser can meet the required cooling capacity.
3. Evaporator, at the same evaporation temperature, such as -35 °C, the thermal conductivity of the gas and liquid in the evaporator is higher than R404A, so the evaporator size can be slightly smaller.
4. Capillary, under the same refrigerating capacity, the capillary size is slightly longer, theoretically about 1.6 times of R404A
5. Charge volume, since the density of R290 is smaller, when the size of evaporator and condenser is unchanged, that is, under the same volume condition, the charging amount is 40%~50% of that of R404A.

>>> 直流压缩机安装说明 DC Compressor Instruction

控制器接线图 Electronic Unit Wiring Diagram

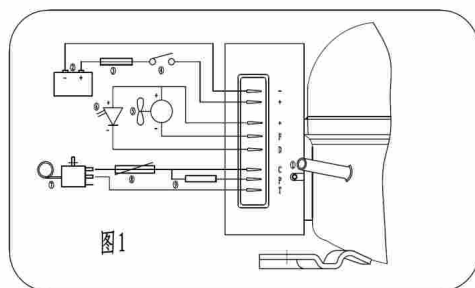

- ① 螺丝钉 Screw
- ② 电池 Battery
- ③ 保险丝 Fuse
- ④ 主开关 Main Switch
- ⑤ 风扇 DC FAN
- ⑥ LED灯 LED Light
- ⑦ 温控 Thermostat
- ⑧ 控速电阻 Resistor for presetting speed
- ⑨ 电池保护电阻 Resistor for presetting battery protection voltage

控制器使用说明 Electronic Unit Specification

- 1、此控制器能自动适应双电压即直流12V和24V电源输入系统，直流12V系统时最大输入电压为17V，24V系统时最大输入电压为31.5V。控制器工作环境温度不大于60℃；当控制器外壳温度过高时将停止压缩机而产生温度过高保护。
- 2、安装方式：如图1所示，将控制器三相输出插件紧插在压缩机的连接线上，控制器套入压缩机的装卡片后拧紧螺钉（1）。
- 3、电源连接：如图1所示。
 - a. 控制器的电源输入线直接连接至电池的正负极（2），控制器的（-）极连至电池的负极；控制器的（+）极连至电池的正极，否则控制器将不能正常工作，控制器具有电源反接保护。
 - b. 为了保护装置，必须在正电源线中接入一个保险丝（3），并尽可能靠近电池的正输出极，QDZH25G, QDZH30G和QDZH35G压缩机推荐12V系统采用15A，24V系统采用7.5A；QDZH65G压缩机推荐12V系统采用30A，24V系统采用15A。
 - c. 如果加入主开关（4），则QDZH25G, QDZH30G和QDZH35G压缩机开关的最小通断电流值大于20A；QDZH65G压缩机开关的最小通断电流值为12VDC-40A或者24VDC-20A。
 - d. 电源线选择（线径及长度）可参照表2，否则会因电源线上的电压降影响到控制器的电池保护点的设置值。
- 4、电池的保护：如图1所示。
 - a. 控制器通过检测输入极（+）和（-）之间的电压值来确定停止压缩机及重启压缩机，用于保护不同的供电电池。
 - b. 标准电池的保护设备推荐值见表3；其他电压的设定可通过调节控制器的端子（C）和（F）的连接电阻（9），具体数值参照表1。
- 5、温度开关：如图1所示。
 - a. 温度开关（7）连接在控制器的C、T端，如果中间不连接任何电阻，则当温度开关闭合时压缩机的运行速度为2000rpm。
 - b. 其他压缩机的设定转速可通过电阻（8）来调节电流（mA）来获得，具体电阻数值参照表4。
- 6、外接风扇：如图1所示。
 - a. 控制器的端子（+）和（F）之间可接入一个12V的直流风扇（5），风扇的正极连接控制器的（+）端，负极连接控制器的（F）端。当控制器的输入电压超过12V时，端子（+）和（F）之间输出的值总是保持12V。不管输入电压系统是12V还是24V，风扇必须是12V的直流风扇。
 - b. 控制器可持续输出0.5A的风扇驱动能力。
- 7、外接LED显示：如图1所示。
 - a. 控制器的端子（+）和（D）之间可接入一个10mA的LED（6）用于显示故障，LED的阳极连接控制器的（+）端，阴极连接控制器的（D）端。
 - b. 当发生故障时，LED每3秒循环，在每个循环中连续闪烁，根据不同的故障闪烁不同的次数，每次闪烁为0.2秒，持续增值3分钟，具体代码和闪烁次数见表5。

Electronic Unit Specification

1. The electronic unit is a dual voltage device. This means that the same unit can be used in both 12V and 24V power supply systems, maximum voltage is 17V for a 12V system and 31.5V for a 24V system. Maximum ambient temperature is 60℃. The electronic unit has a built-in thermal protection which is actuated and stops compressor operation if the electronic unit temperature gets too high.
 2. Installation (Fig.1)

Connect the terminal plug from the electronic unit to the compressor terminal. Mount the electronic unit on the compressor by snapping the cover over the screw head(1).
 3. Power supply (Fig.1)
 - a. The electronic unit must always be connected directly to the battery poles(2), connect the plus to (+) and the minus to (-), otherwise the electronic unit will not work. The electronic unit is protected against reverse battery connection.
 - b. For protection of the installation, a fuse (3) must be mounted in the (+) cable as close to the battery as possible. 15A fuse for 12V and 7.5A fuse for 24V circuits are recommended for model QDZH25G, QDZH30G and QDZH35G; 30A fuse for 12V and 15A fuse for 24V circuits for model QDZH65G.
 - c. If a main switch (4) is used, model QDZH25G, QDZH30G and QDZH35G should be rated to a current of min. 20A; model QDZH65G should be rated to a current of 40A @ 12V and 20V @ 24V.
 - d. The wire dimensions in Table. 2 must be observed. Avoid extra junctions in the power supply system to prevent voltage drop from affecting the battery protection setting.
 4. Battery protection (Fig.1)
 - a. The compressor is stopped and re-started again according to the decided voltage limits measured on the (+) and (-) terminals of the electronic unit.
 - b. The standard settings for 12V and 24V power supply systems appear from Table.3. Other setting (Table.1) are optional if a connection which includes a resistor (9) is established between terminals C and F.
 5. Thermostat switch(Fig.1)
 - a. The thermostat (7) is connected between the terminals C and T. Without any resistor in the control circuit, the compressor with electronic unit will run with a fixed speed of 2000rpm when the thermostat is switched on.
 - b. Other fixed compressor speeds in the range between 2000 and 3500rpm can be obtained when a resistor (8) is installed to adjust the voltage (V) of the control circuit. Resistor values for various motor speeds appear from Table.4.
 6. Fan (Optional, Fig.1)
 - a. A fan (5) can be connected between the terminals (+) and (F). Connect the plus to (+) and the minus to (F). Since the output voltage between the terminals (+) and (F) is always regulated to 12V, a 12V fan must be used for 12V and 24V power supply systems.
 - b. The fan output can supply a continuous current of 0.5A. A higher current draw is allowed for 2 seconds during start.
 7. LED(Optional, Fig.1)
 - a. A 10mA light emitting diode (LED)(6) can be connected between the terminals (+) and (D).
 - b. In case the electronic unit records an operational error, the diodes will flash a number of times. The number of flashes depends on what kind of operational error was recorded. Each flash will last 1/5 second. After the actual number of flashes there will be a delay with no flashes, so that the sequence for each error recording is repeated every 3 minutes.
- 注意事项:**
- 1、控制器通电前，请仔细阅读说明书，并检查连接线是否正确，不正确的连接可能损坏控制器；
 - 2、控制器输入电压值不能大于直流35V。
- Notes:**
1. Power electronic Unit, please read the manual; and check the connection is correct, incorrect connection may damage controller.
 2. Electronic Unit can not be greater than the value of the input voltage 35V.

工作电压设定表 (表1)

Optional battery protection settings (Table 1)

外接电源 Resistor (9)K Ω	12V停机值 12V cut-out V	12V开机值 12V cut-in V	12V高压停机值 12V Max cut-out V	24V停机值 24V cut-out V	24V开机值 24V cut-in V	24V高压停机值 24V Max cut-out V
0.0	9.6	10.9	17.0	21.3	22.7	31.5
1.6	9.7	11.0	17.0	21.5	22.9	31.5
2.4	9.9	11.1	17.0	21.8	23.2	31.5
3.6	10.0	11.3	17.0	22.0	23.4	31.5
4.7	10.1	11.4	17.0	22.3	23.7	31.5
6.2	10.2	11.5	17.0	22.5	23.9	31.5
8.2	10.4	11.7	17.0	22.8	24.2	31.5
11.0	10.5	11.8	17.0	23.0	24.5	31.5
14.0	10.6	11.9	17.0	23.3	24.7	31.5
18.0	10.8	12.0	17.0	23.6	25.0	31.5
24.0	10.9	12.2	17.0	23.8	25.2	31.5
33.0	11.0	12.3	17.0	24.1	25.5	31.5
47.0	11.1	12.4	17.0	24.3	25.7	31.5
82.0	11.3	12.5	17.0	24.6	26.0	31.5
220	9.6	10.9	17.0	21.3	22.7	31.5

电源进线推荐 (表2)

Wire dimensions (Table 2)

线号 AWG Gauge	线径 Cross setion (mm ²)	12V最大长度Max Length 12V DC		24V最大长度Max Length 24V DC	
		ft	m	ft	m
13	2.5	8	2.5	16	5
12	4	13	4	26	8
10	6	20	6	39	12
8	10	23	10	66	20

标准电池保护设定推荐表 (表3)

Standard battery protection settings (Table 3)

12V停机值 12V cut-out V	12V开机值 12V cut-in V	24V停机值 12V cut-out V	24V开机值 24V cut-in V
10.4	11.7	22.8	24.2

速度设定表 (表4)

Compressor speed settings (Table 4)

压缩机转速Motor speed (rpm)	C/T(8)间电阻C/T Resistor(8) Ω	C/T(8)间电流C/T current mA
2000	0	0.87-1.02
2100	51	1.02-1.17
2200	100	1.17-1.32
2300	150	1.32-1.48
2400	200	1.48-1.63
2500	277	1.63-1.78
2600	330	1.78-1.93
2700	400	1.93-2.08
2800	490	2.08-2.24
2900	586	2.24-2.39
3000	692	2.39-2.54
3100	816	2.54-2.69
3200	963	2.69-2.84
3300	1137	2.84-3.0
3400	1331	3.0-3.15
3500	1523	3.15-3.61
Stop	>3000	3.61-5

故障类型表 (表5)

Error Type (Table 5)

闪烁次数 Number of Flashes	故障类型Error Type
1	电压故障--输入电压处于设定的范围之外。 Battery protection cut-out(The voltage is outside the cut-out setting.)
2	风扇电流故障--风扇电流端输出电流大于1A。 Fan over-current cut-out(The fan loads the electronic unit with more than 1A.)
3	压缩机启动故障--压缩机电机堵转或系统压力太大 (>6kg/cm ³) Motor start error (The rotor is blocked or the differential pressure in the refrigeration system is too high (>6kg/cm ³))
4	压缩机最小速度故障--压缩机负荷过大或电机的转速过小。 Minimum motor speed error (If the refrigeration system is too heavily loaded, the motor cannot maintain minimum speed 1850rpm or controller cannot find the rotor position.)
5	控制器温度故障--控制器外壳温度太高 (>75 $^{\circ}$ C)。 Thermal cut-out of electronic unit (if the refrigeration system had too heavily loaded, or if the ambient temperature is high, the electronic unit will run too hot (case temperature >75 $^{\circ}$ C))
6	控制器硬件故障--控制器检测到不正常的参数。 Controller hardware failure (Controller detects abnormal parameters.)

数字温控器 DIGITAL THERMOSTAT

数字温控器具备两路高精度温度探头来采集冰箱冰柜的冷藏冷冻温度，同时与压缩机驱动模块相连，控制压缩机的转速以及启停。温控器上的数码管实时显示冷藏冷冻区的当前温度。在系统出现故障时通过不同的报错形式来定位相应的系统问题。

Digital thermostat has two high precision temperature probes are used to collect the freezing temperature of the refrigerator and is connected with the compressor drive module to control the rotation speed, start and stop of the compressor. The digital tube on the thermostat displays the current temperature of the frozen area in real time. In the case of system failure, the corresponding system problem is located through different error reporting forms.

一、电气参数(Electrical Parameters)

电压范围: 直流12-24V, 极限电压35V。

工作电流: 0.1A。

具备休眠模式。

门灯功能: 门灯电压跟随输入电压。

温度探头精度 $\pm 1^{\circ}\text{C}$ 。

工作环境温度 $-10^{\circ}\text{C} \sim 60^{\circ}\text{C}$, 相对湿度 20% - 90%;

Voltage range: DC12-24V, Limited voltage 35V.

Working current : 0.1A.

With sleep mode.

Gate lamp function: The gate lamp voltage follows the input voltage.

Temperature probe accuracy $\pm 1^{\circ}\text{C}$.

Ambient temperature $-10^{\circ}\text{C} \sim 60^{\circ}\text{C}$, Relative humidity 20% - 90%.

二、外观(Appearance)



三、操作说明(Operation)

1、按键操作(keys operation):



加减设置按键, 支持短按、长按。
Set the add or subtract button. Support short press, long press



设置按键。短按进入温度设置状态, 长按进入菜单选项。
Set Button. Short press to enter the temperature setting state, long press to enter menu options



电压保护档位设置按键, 用于欠压值设定。
Voltage protection guard position setting button, used for setting under voltage value



压缩机运行模式按键。
Compressor operation mode button



开机/关机按键。长按3秒进入休眠模式。
Switch button. Press long for 3 seconds to enter hibernation mode

2、显示内容(Display content):



显示冷冻区域温度。
Displays the temperature of the frozen area



代表选择高速档或节能档。
High gear or energy efficient



显示当前的供电电压。
Displays the current supply voltage



代表选择高档、中档或低档电压保护值。
High, medium or low voltage protection value

四、功能说明(Function)

1. 门灯功能: LED灯板额定工作电压应与输入电压保持一致。开关 led 灯: 短按 ON/OFF 键, 开启或关闭 led 灯。
2. 显示功能: 1) 1个四位(单温)或2个四位(双温)红色数码管显示, 显示范围 $-40^{\circ}\text{C} \sim 50^{\circ}\text{C} / -40^{\circ}\text{F} \sim 104^{\circ}\text{F}$; 当箱内温度低于 $-40^{\circ}\text{C} (-40^{\circ}\text{F})$ 时, 显示 $-40^{\circ}\text{C} (-40^{\circ}\text{F})$; 当箱内温度高于 $50^{\circ}\text{C} (104^{\circ}\text{F})$ 时, 显示 $50^{\circ}\text{C} (104^{\circ}\text{F})$ 。
3. 温度设定 (冷冻停机温度) 调节: 短按 set 按键进入控制温度设定状态, 再按 Δ 或 ∇ 键变更数值并。如不按任何键, 3秒后恢复显示箱内温度。温度设定值带记忆功能。
4. 开机/关机: 按 ON/OFF 键 3 秒, 关闭制冷工作模式, 数码管无显示, 停止所有控制输出, 再按 ON/OFF 键 1 秒, 显示测量温度, 经延时后启动制冷工作模式。
5. 按下欠压设定按键, 可以选择三档欠压值 L/M/H 。

档位	12V 时保护电压	12V 时恢复工作电压	24V 时保护电压	24V 时恢复工作电压
L	10.0V	11V	21.6V	23.0V
M	10.7V	11.7V	22.6V	24.0V
H	11.5V	12.5V	24.6V	26.0V

6. 上电经过延时后, 当箱内温度大于 (控制温度+温度回差), 压缩机启动; 当箱内温度小于等于控制温度时, 压缩机停止。
7. 为防止压缩机频繁启停, 压缩机每次停止的时间必须超过延时时间 (E4 参数) 才能重新启动。
8. 数码管显示的温度=测量温度+温度补偿。
9. 用户设置参数均带有记忆功能, 重新上电后无须重复设置。
10. 复位功能: 进入 RE 菜单, 选择参数 1, 即可恢复所有参数至初始值。
11. 开机自检功能: 数码管、指示灯全显 2 秒 数码管以 000-111.....999 显示, 制冷灯亮 POWER 灯亮, 数码管显示箱内温度。

1. Gate lamp function: The rated working voltage of LED panel should be consistent with the input voltage. Switch the led lamp: short press on or off, turned on or off LED panel.
2. Display function: A fourth (Single temperature) or a forth (Double temperature) red digital tube display, display range $-40^{\circ}\text{C} \sim 50^{\circ}\text{C} / -40^{\circ}\text{F} \sim 104^{\circ}\text{F}$; When the temperature in the box is below $-40^{\circ}\text{C} (-40^{\circ}\text{F})$, it will show $-40^{\circ}\text{C} (-40^{\circ}\text{F})$; When the temperature in the box is above $50^{\circ}\text{C} (104^{\circ}\text{F})$, it will show $50^{\circ}\text{C} (104^{\circ}\text{F})$.
3. Temperature regulation (Freezing shutdown temperature): Short press 'set' enter the control temperature setting state, use Δ or ∇ to change date. If no key is pressed, restore the temperature in the display box after 3 seconds. Temperature setting with memory function.
4. ON/OFF: Press three seconds on ON/OFF, turn off refrigeration mode, no digital display, stop all control output. Press one second on ON/OFF again, display measuring temperature and start the refrigeration operation mode after the delay.
5. Press under voltage setting button, you can choose three levels of under voltage L/M/H .

Gear position	12V Protect the voltage	12V Recovery working voltage	24V Protect the voltage	24V Recovery working voltage
L	10.0V	11V	21.6V	23.0V
M	10.7V	11.7V	22.6V	24.0V
H	11.5V	12.5V	24.6V	26.0V

6. After the current has passed the delay, the compressor starts when the temperature in the box is greater than (Control the temperature+temperature return difference); The compressor starts when the temperature in the box is less than or equal to the control temperature.
7. In order to prevent frequent start and stop of the compressor, the time of each stop must exceed the delay time of (E4 parameter) before the compressor can be restarted.
8. Digital tube display temperature=measure temperature+temperature compensation.
9. User setting parameters are equipped with memory function, there is no need to repeat the setting after the current are reset.
10. Reset function: Enter the RE system and select parameter 1, you can restore all parameters to the initial value.
11. Start automatic detection: Digital tube and the indicator lights are all on for 2 seconds, digital tube with 000-111..... 999 show, refrigeration lights, POWER lights, the digital tube shows the temperature in the box.

一、菜单设置(The Menu Settings)

1. 长按 set 键持续 3 秒后,进入菜单参数设定状态,同时闪烁显示 E1;
2. 再按 Δ 或 ∇ 按键改变参数选择,依序显示 E1、E2、E3、E4、E5、E6、E7、E8、E9、E10、E11、E12、E13、E14、E15 依序循环;
3. 按 + 或 - 键,可显示该参数的数值并修改、存储数据;
4. 6 秒内未再按任何键,返回正常操作方式;

1. Long press on 'set' for 3 seconds to enter the menu parameter setting state, the flash shows the E1 at the same time.
2. Use Δ or ∇ to change parameter, Display in sequence: E1、E2、E3、E4、E5、E6、E7、E8、E9、E10、E11、E12、E13、E14、E15, recycle.
3. Press + / - , display the value of the parameter and modify and store the data.
4. No more keys pressed for 6 seconds, return to normal operation mode.

参数 Parameter	功能Function	设定范围Setting range	出厂值 Factory default
E1	最低控制温度 Minimum control temperature	-40°C ~ 控制温度 -40°C ~ control temperature	-22°C
E2	最高控制温度 Maximum control temperature	控制温度 ~ 40°C control temperature ~ 40°C	+15°C
E3	温度回差 Temperatures return difference	1 ~ 10°C	2°C
E4	停机保护时间 Shutdown protection time	0 ~ 10 分钟 (min)	3 分钟 (min)
E5	测量温度补偿 0 Measurement temperature compensation 0	-10°C ~ 10°C	0°C
E6	测量温度补偿 1 (用于双温 Double temperature) Measurement temperature compensation 1	-10°C ~ 10°C	0°C
E7	高温报警相对值 Relative value of high temperature alarm	0-25	(该款未提供) Unavailable
E8	低温报警相对值 Relative value of low temperature alarm	0-25	(该款未提供) Unavailable
E9	延时开机时间 Delayed start time	0-15 分钟 (min)	0
E10	温度报警延时时间 Temperature alarm delay time	0-60 分钟 (min)	(该款未提供) Unavailable
E11	开机报警延时时间 Start alarm delay time	0-60 小时 (hrs)	(该款未提供) Unavailable
E12	关闭温度设定 close temperature setting	0-10: 可以设定 1: 表示关闭 0-10: setting 1: close	0
CF	华氏摄氏转换 Fahrenheit Celsius conversion	C/F0-1	C
RE	复位出厂设定值 Reset factory Settings	1 表示进行复位 1 Means to reset	0

一、报警功能(Alarm Function)

当压缩机驱动模块运行出现故障时,模块 D 端输出脉冲电平故障信号,温控器收到故障信号进行处理之后,通过数码管分别显示 ER0、ER1、ER2、ER3、ER4、ER5、ER9。当存在故障信号时压缩机停止运转,面板按键功能失效。排出故障 2 秒后,系统回到运行状态。

Er0 故障表示感温头短路,此时压缩机进入定时工作模式,压缩机运行 30 分钟,停止 30 分钟。检查温度探头是否短路,建议更换温度探头。

Er1 故障表示模块输入欠压保护。检查输入电压是否过低,输入引线是否过细导致压降偏大。建议选择电压保护 L 档。

Er2 故障表示直流风扇过流保护。检查风扇是否短路,建议更换风扇。

Er3 故障表示压缩机启动异常保护。确认系统压力是否过大,建议等待 3 分钟后重新启动。

Er4 故障表示压缩机转速异常保护。确认系统压力是否过大,建议等待 3 分钟后重新启动。

Er5 故障表示模块温度异常保护。建议加强压缩机驱动模块通风条件。

Er9 故障表示感温头断路,此时压缩机进入定时工作模式,压缩机运行 30 分钟,停止 30 分钟。请检查温度探头是否断路,接口是否松动,建议更换温度探头。

1. When the compressor driver module runs in fault, module D output pulse level fault signal. After the thermostat receives the fault signal for processing, it displays ER0, ER1, ER2, ER3, ER4, ER5 and ER9 respectively through the digital tube. When there is a fault signal, the compressor stops operation, and the function of the panel key is invalid. 2 seconds after the failure, the system returned to operation.

2. ER0 fault indicates short circuit of temperature sensor head. At this time, the compressor enters the regular working mode. The compressor runs for 30 minutes and stops for 30 minutes. Check whether the temperature probe is short-circuited and suggest to replace the temperature probe.

3. ER1 failure indicates module input undervoltage protection. Check whether the input voltage is too low and whether the input lead is too thin, resulting in a large voltage drop. Suggest to choose Voltage protection L.

4. ER2 failure indicates dc fan overcurrent protection. Check the fan for short circuit and suggest to replace the fan.

5. ER3 failure indicates compressor start up abnormal protection. Confirm if the system pressure is too high. It is recommended to wait 3 minutes before restarting.

6. ER4 Fault indicates abnormal compressor speed protection. Confirm if the system pressure is too high. It is recommended to wait 3 minutes before restarting.

7. ER5 failure indicates module temperature anomaly protection. It is suggested to strengthen the ventilation condition of compressor drive module.

8. ER9 fault indicates that the temperature sensing head is broken. At this time, the compressor enters the timing working mode. The compressor runs for 30 minutes and stops for 30 minutes. Please check whether the temperature probe is broken and the interface is loose. It is recommended to replace the temperature probe.

直流压缩机 / DC COMPRESSOR

R134a LBP M/HBP 12/24V

产品系列 Serial	产品型号 Model	排量 Displacement(cm ³)	转速 Rotate Speed	制冷量 Capacity			性能系数		油充量 Oil charge ml	冷媒类型 Cooling	电源 Power Supply	认证 Certificate
				测试工况 Test Conditions: -23.3°C(-10F)			COP	EER				
				W	Kcal/h	Btu/h						
L	QDZH15G	1.5	2000	30	26	102	0.95	3.24	130	F	12/24V (DC)	CE
			2500	35	30	120	0.96	3.27				
			3000	42	36	143	0.96	3.27				
			3500	50	44	170	1.00	3.41				
	QDZH20G	2.0	2000	40	34	136	0.98	3.34				
			2500	48	41	163	0.98	3.34				
			3000	57	49	194	1.00	3.41				
			3500	65	56	221	1.00	3.41				
	QDZH25G	2.5	2000	43	37.2	146	1.08	3.68				
			2500	53	46	186	1.05	3.58				
			3000	62	54	211	1.06	3.62				
			3500	72	62	245	1.04	3.55				
	QDZH30G	3.0	2000	52	45	176	1.05	3.58				
			2500	64	55	217	1.05	3.58				
			3000	75	64	254	1.06	3.62				
			3500	87	75	295	1.04	3.55				
	QDZH35G	3.5	2000	60	52	205	1.08	3.68				
			2500	73	63	249	1.07	3.65				
			3000	86	74	293	1.06	3.62				
	QDZH43G	4.3	2500	100	87	341	1.05	3.58				
			2000	80	69	273	1.15	3.92				
			2500	96	83	328	1.20	4.09				
			3000	115	99	392	1.25	4.27				
	QDZH50G	5.0	2000	138	119	471	1.25	4.27				
2000			87	75	297	1.17	3.99					
2500			104	90	355	1.13	3.86					
3000			130	112	444	1.35	4.61					
QDZH65G	6.5	3500	163	141	556	1.20	4.09					
		2000	120	104	409	1.20	4.09					
		2500	150	130	512	1.20	4.09					
		3000	180	156	614	1.20	4.09					
QDZH75G	7.5	3500	210	181	717	1.20	4.09					
		2000	146	125	499	1.20	4.09					
		2500	183	156	625	1.20	4.09					
		3000	220	189	752	1.20	4.09					
QDZH91G	9.1	3500	256	219	875	1.20	4.09					
		2000	180	154	615	1.20	4.09					
		2500	225	193	769	1.20	4.09					
		3000	270	231	923	1.20	4.09					
			3500	315	270	1077	1.20	4.09				

R600a LBP M/HBP 12/24V

产品系列 Serial	产品型号 Model	排量 Displacement(cm ³)	转速 Rotate Speed	制冷量 Capacity			性能系数		油充量 Oil charge ml	冷媒类型 Cooling	电源 Power Supply	认证 Certificate
				测试工况 Test Conditions: -23.3°C(-10F)			COP	EER				
				W	Kcal/h	Btu/h						
L	QDZY35G	3.5	2000	42	36	143	1.15	3.92	130	F	12/24V (DC)	CE
			2500	50	42	171	1.25	4.27				
			3000	60	52	205	1.35	4.61				
			3500	72	62	246	1.30	4.44				
	QDZY43G	4.3	2000	49	42	167	1.15	3.92				
			2500	61	53	208	1.25	4.27				
			3000	76	66	259	1.35	4.61				
			3500	95	82	324	1.30	4.44				
	QDZY50G	5.0	2000	60	52	205	1.15	3.92				
			2500	72	62	246	1.25	4.27				
			3000	86	74	293	1.35	4.61				
			3500	108	93	369	1.30	4.44				
	QDZY65G	6.5	2000	67	58	229	1.15	3.92				
			2500	93	80	317	1.25	4.27				
			3000	110	95	375	1.35	4.61				
			3500	131	113	447	1.30	4.44				
	QDZY75G	7.5	2000	91	79	311	1.15	3.92				
			2500	108	93	369	1.25	4.27				
			3000	130	112	444	1.35	4.61				
			3500	156	135	532	1.30	4.44				

压缩机技术参数 / COMPRESSOR TECHNICAL DATA

R600a 低背压压缩机 电压220-240V~50/60Hz 普效型

R600a LBP 220-240V~50/60Hz OE

产品系列 Serial	产品型号 Model	马力HP	电压 频率 V/Hz	排量 Displacement(cm³)	制冷量 Cooling Capacity ASHRAE																				电机类型 Motor type	启动器 Starting Device	启动电容 Starting capacitor (µF)	运行电容 Running capacitor (µF)	冷却方式 Cooling	认证 Certificate		
					-35°C (-31F)		-30°C (-22F)		-25°C (-13F)		测试工况 Test Conditions: -23.3°C (-10F)						-20°C (-4F)		-15°C (5F)		-10°C (10F)		-5°C (23F)								0°C (32F)	
					W	Btu/h	W	Btu/h	W	Btu/h	制冷量 Capacity (W)	制冷量 Capacity (Btu/h)	输入功率 Input Power (W)	电流 Current (A)	COP (W/W)	EER (Btu/Wh)	W	Btu/h	W	Btu/h	W	Btu/h	W	Btu/h							W	Btu/h
L	QD35YG	1/12	220-240V/50-60Hz	3.5	26	89	33	113	43	147	56	191	47	0.38	1.20	4.10	70	239	86	293	109	372	137	467	171	583	RSIR	PTC Starting Relay	/	/	ST	CCC CB CE
	QD43YG	1/11		4.3	34	116	44	150	58	198	75	256	62	0.45	1.20	4.10	94	321	117	399	147	502	183	624	229	781	RSIR		/	/	ST	CCC CB CE
	QD53YG	1/9		5.3	39	133	50	171	65	222	85	290	65	0.50	1.30	4.43	106	362	133	454	166	566	208	710	259	884	RSIR		/	/	ST	CCC CB CE
	QD65YG	1/7		6.5	50	171	65	222	85	290	110	375	85	0.55	1.30	4.43	138	471	172	587	215	734	269	918	336	1146	RSIR		/	/	ST	CCC CB CE
	QD69YG	1/7+		6.9	55	187	72	246	93	317	120	409	92	0.60	1.30	4.43	152	519	186	635	232	792	295	1007	365	1245	RSIR		/	/	ST	CCC CB CE
	QD75YG	1/6-		7.5	59	201	77	263	100	341	130	444	100	0.70	1.30	4.43	163	556	203	693	254	867	317	1082	397	1355	RSIR		/	/	ST	CCC CB CE
ML	QD75YG	1/6-		7.5	59	201	77	263	100	341	130	444	100	0.70	1.40	4.77	163	556	203	693	254	867	317	1082	397	1355	RSIR		/	/	ST	CCC CB CE
	QD85YG	1/6		8.5	66	225	86	293	112	382	145	495	112	0.75	1.40	4.77	181	618	227	775	283	966	354	1208	443	1512	RSIR		/	/	ST	CCC CB CE
	QD91YG	1/5		9.1	71	242	92	314	119	406	155	529	106	0.80	1.45	4.95	194	662	242	826	303	1034	378	1290	473	1614	RSIR		/	/	ST	CCC CB CE
	QD103YG	1/4-		10.3	77	263	99	338	130	444	168	573	115	0.85	1.45	4.95	210	717	263	897	328	1119	410	1399	513	1750	RSIR		/	/	ST	CCC CB CE
	QD110YG	1/4		11.0	84	287	109	372	142	485	190	648	126	0.95	1.50	5.12	231	788	289	986	361	1232	452	1542	565	1928	RSIR		/	/	ST	CCC CB CE
MX	QD85YG	1/6		8.5	66	225	86	293	112	382	148	505	95	0.75	1.55	5.28	181	618	227	775	283	966	354	1208	443	1512	RSIR		/	/	ST	CCC CB CE
	QD91YG	1/5		9.1	71	242	92	314	119	406	158	539	101	0.70	1.55	5.28	194	662	242	826	303	1034	378	1290	473	1614	RSIR		/	/	ST	CCC CB CE
	QD103YG	1/4-		10.3	77	263	99	338	130	444	170	580	113	0.85	1.50	5.12	210	717	263	897	328	1119	410	1399	513	1750	RSIR		/	/	ST	CCC CB CE
	QD110YG	1/4		11.0	84	287	109	372	142	485	190	648	127	0.95	1.50	5.12	231	788	289	986	361	1232	452	1542	565	1928	RSIR		/	/	ST	CCC CB CE
	QD128YG	1/3-		12.8	100	341	130	444	169	577	215	734	159	1.05	1.35	4.61	275	938	344	1174	430	1467	537	1832	671	2289	RSIR		/	/	ST	CCC CB CE
MQ	QD128YG	1/3-		12.8	100	341	130	444	169	577	220	751	152	1.05	1.45	4.95	275	938	344	1174	430	1467	537	1832	671	2289	RSIR		/	/	F	CCC CB CE
	QD142YG	1/3		14.2	109	372	142	485	185	631	240	819	166	1.15	1.45	4.95	300	1024	375	1280	469	1600	586	1999	732	2498	RSIR		/	/	F	CCC CB CE
	QD153YG	1/3+	15.3	118	403	154	525	200	682	260	887	179	1.25	1.45	4.95	325	1109	406	1385	508	1733	635	2167	794	2709	RSIR	/	/	F	CCC CB CE		

压缩机技术参数 / COMPRESSOR TECHNICAL DATA

R600a 低背压压缩机 电压220-240V~50/60Hz 高效型

R600a LBP 220-240V~50/60Hz HE

产品系列 Serial	产品型号 Model	马力HP	电压 频率 V/Hz	排量 Displacement(cm ³)	制冷量 Cooling Capacity ASHRAE																				电机类型 Motor type	启动器 Starting Device	启动电容 Starting capacitor (uF)	运行电容 Running capacitor (uF)	冷却方式 Cooling	认证 Certificate		
					-35°C (-31F)		-30°C (-22F)		-25°C (-13F)		测试工况 Test Conditions: -23.3°C (-10F)						-20°C (-4F)		-15°C (5F)		-10°C (10F)		-5°C (23F)								0°C (32F)	
					W	Btu/h	W	Btu/h	W	Btu/h	制冷量 Capacity (W)	制冷量 Capacity (Btu/h)	输入功率 Input Power (W)	电流 Current (A)	COP (W/W)	EER (Btu/Wh)	W	Btu/h	W	Btu/h	W	Btu/h	W	Btu/h							W	Btu/h
L	QD35YV	1/12	220-240V/50-60Hz	3.5	26	89	33	113	43	147	56	191	44	0.30	1.25	4.26	70	239	86	293	109	372	137	467	171	583	RSCR	PTC Starting Relay	/	3	ST	CCC CB CE
	QD43YV	1/11		4.3	34	116	44	150	58	198	75	256	57	0.32	1.30	4.43	94	321	117	399	147	502	183	624	229	781	RSCR		/	3	ST	CCC CB CE
	QD53YV	1/9		5.3	39	133	50	171	65	222	85	290	62	0.40	1.35	4.60	106	362	133	454	166	566	208	710	259	884	RSCR		/	3	ST	CCC CB CE
	QD65YV	1/7		6.5	50	171	65	222	85	290	110	375	78	0.45	1.40	4.77	138	471	172	587	215	734	269	918	336	1146	RSCR		/	3	ST	CCC CB CE
ML	QD69YV	1/7+		6.9	55	187	72	246	93	317	120	409	80	0.50	1.50	5.12	152	519	186	635	232	792	295	1007	365	1245	RSCR		/	3	ST	CCC CB CE
	QD75YV	1/6-		7.5	59	201	77	263	100	341	130	444	83	0.55	1.55	5.28	163	556	203	693	254	867	317	1082	397	1355	RSCR		/	4	ST	CCC CB CE
	QD85YV	1/6		8.5	66	225	86	293	112	382	145	495	90	0.60	1.60	5.46	181	618	227	775	283	966	354	1208	443	1512	RSCR		/	4	ST	CCC CB CE
	QD91YV	1/5		9.1	71	242	92	314	119	406	155	529	96	0.65	1.60	5.46	194	662	242	826	303	1034	378	1290	473	1614	RSCR		/	4	ST	CCC CB CE
MX	QD60YV	1/7-		6.0	46	157	60	205	78	266	105	358	57	0.34	1.75	5.97	122	416	156	532	235	802	248	846	310	1058	RSCR		/	4	ST	CCC CB CE
	QD65YV	1/7		6.5	50	171	65	222	85	290	110	375	62	0.36	1.75	5.97	138	471	172	587	215	734	269	918	336	1146	RSCR		/	4	ST	CCC CB CE
	QD75YV	1/6-		7.5	59	201	77	263	100	341	130	444	74	0.38	1.75	5.97	163	556	203	693	254	867	317	1082	397	1355	RSCR		/	4	ST	CCC CB CE
	QD85YV	1/6		8.5	66	225	86	293	112	382	145	495	82	0.40	1.75	5.97	181	618	227	775	283	966	354	1208	443	1512	RSCR		/	4	ST	CCC CB CE
	QD91YV	1/5		9.1	71	242	92	314	119	406	155	529	88	0.45	1.75	5.97	194	662	242	826	303	1034	378	1290	473	1614	RSCR		/	4	ST	CCC CB CE
	QD103YV	1/4-		10.3	77	263	99	338	130	444	168	573	96	0.48	1.75	5.97	210	717	263	897	328	1119	410	1399	513	1750	RSCR		/	4	ST	CCC CB CE
	QD110YV	1/4		11.0	84	287	109	372	142	485	185	631	105	0.52	1.75	5.97	231	788	289	986	361	1232	452	1542	565	1928	RSCR		/	4	ST	CCC CB CE
QD126YV	1/3-	12.6		100	341	130	444	169	577	220	751	125	0.65	1.75	5.97	275	938	344	1174	430	1467	537	1832	671	2289	RSCR	/		4	ST	CCC CB CE	
MQ	QD128YV	1/3-		12.8	100	341	130	444	169	577	220	751	129	0.70	1.70	5.80	275	938	344	1174	430	1467	537	1832	671	2289	RSCR		/	5	F	CCC CB CE
	QD142YV	1/3		14.2	109	372	142	485	185	631	240	819	141	0.75	1.70	5.80	300	1024	375	1280	469	1600	586	1999	732	2498	RSCR		/	5	F	CCC CB CE
	QD153YV	1/3+		15.3	118	403	154	525	200	682	260	887	152	0.80	1.70	5.80	325	1109	406	1385	508	1733	635	2167	794	2709	RSCR		/	5	F	CCC CB CE

压缩机技术参数 / COMPRESSOR TECHNICAL DATA

R600a 低背压压缩机 电压220-240V~50/60Hz 超高效型

R600a LBP 220-240V~50/60Hz HE

产品系列 Serial	产品型号 Model	马力HP	电压 频率 V/Hz	排量 Displacement (cm ³)	制冷量 Cooling Capacity ASHRAE																		电机类别 Motor type	启动器 Starting Device	启动电容 Starting capacitor (uF)	运行电容 Running capacitor (uF)	冷却方式 Cooling	认证 Certificate							
					-35°C (-31F)			-30°C (-22F)			-25°C (-13F)			测试工况 Test Conditions: -23.3°C (-10F)						-20°C (-4F)		-15°C (5F)							-10°C (10F)		-5°C (23F)		0°C (32F)		
					W	Btu/h		W	Btu/h		W	Btu/h		制冷量 Capacity (W)	制冷量 Capacity (Btu/h)	输入功率 Input Power (W)	电流 Current (A)	COP (W/W)	EER (Btu/Wh)	W	Btu/h	W							Btu/h	W	Btu/h	W	Btu/h	W	Btu/h
MX	QD53YVV	1/9	220-240V/50-60Hz	5.3	39	133	50	171	65	222	88	300	48	0.32	1.80	6.14	106	362	133	454	166	566	208	710	259	884	RSCR	PTC Starting Relay	/	3	ST	CCC CB CE			
	QD60YVV	1/8		6.0	59	201	77	263	100	341	100	341	55	0.34	1.80	6.14	163	556	203	693	254	867	317	1082	397	1355	RSCR		/	3	ST	CCC CB CE			
	QD65YVV	1/7		6.5	50	171	65	222	85	290	110	375	61	0.36	1.80	6.14	138	471	172	587	215	734	269	918	336	1146	RSCR		/	3	ST	CCC CB CE			
	QD69YVV	1/7+		6.9	55	187	72	246	93	317	118	403	65	0.38	1.80	6.14	152	519	186	635	232	792	295	1007	365	1245	RSCR		/	4	ST	CCC CB CE			
	QD75YVV	1/6-		7.5	59	201	77	263	100	341	125	427	70	0.42	1.80	6.14	163	556	203	693	254	867	317	1082	397	1355	RSCR		/	4	ST	CCC CB CE			
	QD85YVV	1/6		8.5	66	225	86	293	112	382	145	495	80	0.46	1.80	6.14	181	618	227	775	283	966	354	1208	443	1512	RSCR		/	4	ST	CCC CB CE			
	QD91YV V	1/5		9.1	71	242	92	314	119	406	155	529	86	0.52	1.80	6.14	194	662	242	826	303	1034	378	1290	473	1614	RSCR		/	4	ST	CCC CB CE			
	QD103YVV	1/4-		10.3	77	263	99	338	130	444	168	573	93	0.58	1.80	6.14	210	717	263	897	328	1119	410	1399	513	1750	RSCR		/	4	ST	CCC CB CE			
	QD110YVV	1/4		11.0	84	287	109	372	142	485	185	631	102	0.62	1.80	6.14	231	788	289	986	361	1232	452	1542	565	1928	RSCR		/	4	F	CCC CB CE			
	QD128YVV	1/3-		12.8	100	341	130	444	169	577	215	734	122	0.65	1.80	6.14	275	938	344	1174	430	1467	537	1832	671	2289	RSCR		/	4	F	CCC CB CE			

R600a 低背压压缩机 电压110-120V~60Hz 普效型

R600a LBP 110-120V~60Hz OE

产品系列 Serial	产品型号 Model	马力HP	电压 频率 V/Hz	排量 Displacement (cm ³)	制冷量 Cooling Capacity ASHRAE																		电机类别 Motor type	启动器 Starting Device	启动电容 Starting capacitor (uF)	运行电容 Running capacitor (uF)	冷却方式 Cooling	认证 Certificate							
					-35°C (-31F)			-30°C (-22F)			-25°C (-13F)			测试工况 Test Conditions: -23.3°C (-10F)						-20°C (-4F)		-15°C (5F)							-10°C (10F)		-5°C (23F)		0°C (32F)		
					W	Btu/h		W	Btu/h		W	Btu/h		制冷量 Capacity (W)	制冷量 Capacity (Btu/h)	输入功率 Input Power (W)	电流 Current (A)	COP (W/W)	EER (Btu/Wh)	W	Btu/h	W							Btu/h	W	Btu/h	W	Btu/h	W	Btu/h
L	QD35Y11G	1/12	110-120V/50-60Hz	3.5	31	106	40	136	52	177	67	229	56	0.40	1.20	4.08	84	287	105	358	131	447	164	560	205	699	RSCR	PTC Starting Relay	/	6	ST	ETL			
	QD43Y11G	1/11		4.3	41	140	53	181	69	235	90	307	75	0.60	1.20	4.09	113	386	141	481	176	601	220	751	275	938	RSCR		/	6	ST	ETL			
	QD53Y11G	1/9		5.3	47	160	61	208	79	270	102	348	78	1.10	1.30	4.46	128	437	159	543	199	679	249	850	311	1061	RSCR		/	6	ST	ETL			
	QD65Y11G	1/7		6.5	60	205	78	266	102	348	132	450	101	1.45	1.30	4.46	165	563	206	703	258	880	322	1099	403	1375	RSCR		/	6	ST	ETL			
ML	QD75Y11G	1/6-		7.5	71	242	92	314	120	409	156	532	120	1.65	1.30	4.44	195	665	244	833	305	1041	381	1300	476	1624	RSCR		/	6	ST	ETL			
	QD85Y11G	1/6		8.5	79	270	103	351	134	457	174	594	134	1.68	1.30	4.43	218	744	272	928	340	1160	425	1450	531	1812	RSCR		/	6	ST	ETL			
	QD91Y11G	1/5		9.1	85	290	110	375	143	488	186	635	124	1.70	1.50	5.12	233	795	291	993	363	1239	454	1549	568	1938	RSCR		/	6	ST	ETL			
MX	QD103Y11G	1/4-		10.3	92	314	119	406	155	529	201	686	134	1.83	1.50	5.12	251	856	314	1071	393	1341	491	1675	613	2092	RSCR		/	6	ST	ETL			
	QD110Y11G	1/4		11.0	100	341	130	444	169	577	220	751	147	1.95	1.50	5.11	275	938	344	1174	430	1467	537	1832	671	2289	RSCR		/	6	ST	ETL			
MQ	QD128Y11G	1/3-		12.8	120	409	156	532	203	693	264	901	182	2.05	1.45	4.95	330	1126	413	1409	516	1761	645	2201	806	2750	RSCR		/	6	F	ETL			
	QD142Y11G	1/3		14.2	130	444	169	577	219	747	285	972	197	2.16	1.45	4.94	356	1215	445	1518	557	1900	696	2375	870	2968	RSCR		/	6	F	ETL			
	QD153Y11G	1/3+		15.3	142	485	185	631	240	819	312	1065	215	2.25	1.45	4.95	390	1331	485	1655	609	2078	762	2600	952	3248	RSCR		/	6	F	ETL			

压缩机技术参数 / COMPRESSOR TECHNICAL DATA

印度市场专用压缩机 INDIA MARKET COMPRESSOR

R600a 低背压压缩机 电压160-260V~50Hz 普效型

R600a LBP 160-260V 50Hz OE

产品系列 Serial	产品型号 Model	马力HP	电压 频率 V/Hz	排量 Displacement (cm ³)	制冷量 Cooling Capacity ASHRAE																				电机类型 Motor type	启动继电器 Starting Device	启动电容 Starting capacitor (uF)	运行电容 Running capacitor (uF)	冷却方式 Cooling	认证 Certificate				
					-35°C (-31F)			-30°C (-22F)			-25°C (-13F)			测试工况 Test Conditions: -23.3°C (-10F)					-20°C (-4F)		-15°C (5F)		-10°C (10F)								-5°C (23F)		0°C (32F)	
					W	Btu/h		W	Btu/h		W	Btu/h		制冷量 Capacity (W)	制冷量 Capacity (Btu/h)	输入功率 Input Power (W)	电流 Current (A)	COP (W/W)	EER (Btu/Wh)	W	Btu/h	W	Btu/h	W							Btu/h	W	Btu/h	W
L	QD35YG	1/12	160V-260V/50Hz	3.5	26	89	33	113	43	147	56	191	47	0.38	1.20	4.07	70	239	86	293	109	372	137	467	171	583	RSIR	PTC Starting Relay	/	/	ST	CCC CB CE		
	QD43YG	1/11		4.3	34	116	44	150	58	198	75	256	62	0.45	1.20	4.13	94	321	117	399	147	502	183	624	229	781	RSIR		/	/	ST	CCC CB CE		
	QD53YG	1/9		5.3	39	133	50	171	65	222	85	290	65	0.50	1.30	4.46	106	362	133	454	166	566	208	710	259	884	RSIR		/	/	ST	CCC CB CE		
	QD65YG	1/7		6.5	50	171	65	222	85	290	110	375	85	0.52	1.30	4.42	138	471	172	587	215	734	269	918	336	1146	RSIR		/	/	ST	CCC CB CE		
	QD69YG	1/7+		6.9	55	187	72.00	246	93	317	120	409	92	0.55	1.30	4.45	152	519	186	635	232	792	295	1007	365	1245	RSIR		/	/	ST	CCC CB CE		
ML	QD75YG	1/6-		7.5	59	201	77	263	100	341	130	444	100	0.60	1.40	4.44	163	556	203	693	254	867	317	1082	397	1355	RSIR		/	/	ST	CCC CB CE		
	QD85YG	1/6		8.5	66	225	86	293	112	382	145	495	112	0.75	1.40	4.42	181	618	227	775	283	966	354	1208	443	1512	RSIR		/	/	ST	CCC CB CE		
	QD91YG	1/5		9.1	71	242	92	314	119	406	155	529	104	0.70	1.50	5.09	194	662	242	826	303	1034	378	1290	473	1614	RSIR		/	/	ST	CCC CB CE		
	QD103YG	1/4-		10.3	77	263	99	338	130	444	168	573	112	0.85	1.50	5.12	210	717	263	897	328	1119	410	1399	513	1750	RSIR		/	/	ST	CCC CB CE		
MX	QD85YG	1/6		8.5	66	225	86	293	112	382	145	495	112	0.75	1.60	4.42	181	618	227	775	283	966	354	1208	443	1512	RSIR		/	/	ST	CCC CB CE		
	QD91YG	1/5		9.1	71	242	92	314	119	406	155	529	104	0.70	1.60	5.09	194	662	242	826	303	1034	378	1290	473	1614	RSIR		/	/	ST	CCC CB CE		
	QD103YG	1/4-		10.3	77	263	99	338	130	444	168	573	112	0.85	1.60	5.12	210	717	263	897	328	1119	410	1399	513	1750	RSIR		/	/	ST	CCC CB CE		
	QD110YG	1/4		11.0	84	287	109	372	142	485	185	631	124	0.95	1.60	5.09	231	788	289	986	361	1232	452	1542	565	1928	RSIR		/	/	ST	CCC CB CE		
MQ	QD128YG	1/3-		12.8	100	341	130	444	169	577	220	751	152	1.05	1.45	4.94	275	938	344	1174	430	1467	537	1832	671	2289	RSIR		/	/	F	CCC CB CE		
	QD142YG	1/3		14.2	109	372	142	485	185	631	240	819	166	1.15	1.45	4.93	300	1024	375	1280	469	1600	586	1999	732	2498	RSIR		/	/	F	CCC CB CE		
	QD153YG	1/3+	15.3	118	403	154	525	200	682	260	887	179	1.25	1.45	4.96	325	1109	406	1385	508	1733	635	2167	794	2709	RSIR	/	/	F	CCC CB CE				

压缩机技术参数 / COMPRESSOR TECHNICAL DATA

R134a 低背压压缩机 电压220-240V~50/60Hz 普效款

R134a LBP 220-240V~50/60Hz OE

产品系列 Serial	产品型号 Model	马力HP	电压 频率 V/Hz	气量 Displacement (cm ³)	制冷量 Cooling Capacity ASHRAE																				电机类别 Motor type	启动继电器 Starting Device	启动电容 Starting capacitor (uF)	运行电容 Running capacitor (uF)	冷却方式 Cooling	认证 Certificate				
					-35°C (-31F)			-30°C (-22F)			-25°C (-13F)			测试工况 Test Conditions: -23.3°C (-10F)					-20°C (-4F)		-15°C (5F)		-10°C (10F)								-5°C (23F)		0°C (32F)	
					W	Btu/h		W	Btu/h		W	Btu/h		制冷量 Capacity (W)	制冷量 Capacity (Btu/h)	输入功率 Input Power (W)	电流 Current (A)	COP (W/W)	EER (Btu/Wh)	W	Btu/h	W	Btu/h	W							Btu/h	W	Btu/h	W
L	QD25HG	1/12	220-240V/50-60Hz	2.5	25	85	33	113	42	143	55	188	52	0.6	1.05	3.61	69	235	86	293	107	365	134	457	168	573	RSIR	PTC Starting Relay	/	/	ST	CCC CB CE		
	QD30HG	1/12		3.0	30	102	39	133	50	171	65	222	62	0.6	1.05	3.58	81	276	102	348	127	433	159	543	198	676	RSIR		/	/	ST	CCC CB CE		
	QD35HG	1/11		3.5	34	116	44	150	58	198	75	256	71	0.7	1.05	3.60	94	321	117	399	147	502	183	624	229	781	RSIR		/	/	ST	CCC CB CE		
XL	ADW43	1/6-		4.3	50	171	65	222	85	290	110	375	100	1.0	1.10	3.75	138	471	172	587	215	734	269	918	336	1146	RSIR		/	/	ST	CCC CB CE		
	ADW51	1/6		5.1	57	194	74	252	96	328	125	427	104	1.1	1.20	4.10	156	532	195	665	244	833	305	1041	382	1303	RSIR		/	/	ST	CCC CB CE		
ML	ADW51	1/6		5.1	57	194	74	252	96	328	125	427	104	1.1	1.20	4.10	156	532	195	665	244	833	305	1041	382	1303	RSIR		/	/	ST	CCC CB CE		
	ADW57	1/5-		5.7	62	212	80	273	104	355	135	461	112	1.2	1.20	4.11	170	580	211	720	264	901	330	1126	412	1406	RSIR		/	/	ST	CCC CB CE		
	ADW66	1/4-		6.6	75	256	98	334	127	433	165	563	132	1.2	1.25	4.27	206	703	258	880	322	1099	403	1375	504	1720	RSIR		/	/	ST	CCC CB CE		
	ADW77	1/4		7.7	84	287	109	372	142	485	185	631	148	1.3	1.25	4.27	231	788	289	986	361	1232	452	1542	565	1928	RSIR		/	/	ST	CCC CB CE		
MX	ADW66	1/4-		6.6	75	256	98	334	127	433	165	563	132	1.2	1.25	4.27	206	703	258	880	322	1099	403	1375	504	1720	RSIR		/	/	ST	CCC CB CE		
	ADW77	1/4		7.7	84	287	109	372	142	485	185	631	148	1.3	1.25	4.27	231	788	289	986	361	1232	452	1542	565	1928	RSIR		/	/	ST	CCC CB CE		
	ADW86	1/4+		8.6	91	310	118	403	154	525	200	682	160	1.4	1.25	4.27	245	836	310	1058	408	1392	502	1713	596	2034	RSIR		/	/	ST	CCC CB CE		
	ADW91	1/3-	9.1	100	341	130	444	169	577	220	751	176	1.4	1.25	4.27	275	938	344	1174	430	1467	537	1832	671	2289	RSIR	/	/	ST	CCC CB CE				
	ADW110	1/3	11.0	123	420	160	546	208	710	275	938	203	1.4	1.35	4.62	338	1153	422	1440	527	1798	659	2249	824	2811	RSIR	/	/	ST	CCC CB CE				
MQ	ADW91	1/3-	9.1	100	341	133	454	169	577	220	751	162	1.2	1.35	4.63	275	938	344	1174	430	1467	537	1832	671	2289	RSIR	Current Starting Relay	/	/	F	CCC CB CE			
	ADW110	1/3	11.0	123	420	160	546	208	710	270	921	200	1.4	1.35	4.61	338	1153	422	1440	527	1798	659	2249	824	2811	RSIR		/	/	F	CCC CB CE			
	ADW128	3/8+	12.8	146	498	189	645	246	839	320	1092	237	1.8	1.35	4.61	400	1365	500	1706	625	2133	781	2665	977	3334	CSIR		50	/	F	CCC CB CE			
	ADW142	1/2-	14.2	159	543	207	706	269	918	350	1194	260	1.9	1.35	4.59	438	1494	547	1866	684	2334	828	2825	1068	3644	CSIR		50	/	F	CCC CB CE			
	ADW153	1/2	15.3	173	590	225	768	292	996	380	1297	281	2.0	1.35	4.61	475	1621	594	2027	742	2532	855	2917	1160	3958	CSIR		50	/	F	CCC CB CE			
	ADW168	1/2+	16.8	198	676	252	860	330	1126	430	1467	318	2.2	1.35	4.61	512	1747	643	2194	798	2723	885	3020	1250	4265	CSIR		50	/	F	CCC CB CE			

压缩机技术参数 / COMPRESSOR TECHNICAL DATA

R134a 低背压压缩机 电压220-240V~50/60Hz 高效款

R134a LBP 220-240V~50/60Hz HE

产品系列 Serial	产品型号 Model	马力HP	电压 频率 V/Hz	制冷剂 Displacement (cm ³)	制冷量 Cooling Capacity ASHRAE																		电机类别 Motor type	启动继电器 Starting Device	启动电容 (uF)	运行电容 (uF)	冷却方式 Cooling	认证 Certificate							
					-35°C (-31F)			-30°C (-22F)			-25°C (-13F)			测试工况 Test Conditions: -23.3°C (-10F)						-20°C (-4F)		-15°C (5F)							-10°C (10F)		-5°C (23F)		0°C (32F)		
					W	Btu/h		W	Btu/h		W	Btu/h		制冷量 Capacity (W)	制冷量 Capacity (Btu/h)	输入功率 Input Power (W)	电流 Current (A)	COP (W/W)	EER (Btu/Wh)	W	Btu/h	W							Btu/h	W	Btu/h	W	Btu/h	W	Btu/h
L	QD25HV	1/12	220-240V/50-60Hz	2.5	25	85	33	113	42	143	55	188	47	0.55	1.15	3.99	69	235	86	293	107	365	134	457	168	573	RSCR	PTC Starting Relay	/	3	ST	CCC CB CE			
	QD30HV	1/12		3.0	30	102	39	133	50	171	65	222	50	0.63	1.30	4.44	81	276	102	348	127	433	159	543	198	676	RSCR	/	3	ST	CCC CB CE				
XL	QD35HV	1/11		3.5	34	116	44	150	58	198	75	256	57	0.68	1.30	4.49	94	321	117	399	147	502	183	624	229	781	RSCR	/	3	ST	CCC CB CE				
	ADW43HV	1/6-		4.3	50	171	65	222	85	290	110	375	71	0.65	1.55	5.29	138	471	172	587	215	734	269	918	336	1146	RSCR	/	4	ST	CCC CB CE				
ML	ADW51HV	1/6		5.1	57	194	74	252	96	328	125	427	81	0.70	1.55	5.27	156	532	195	665	244	833	305	1041	382	1303	RSCR	/	4	ST	CCC CB CE				
	ADW57HV	1/5-		5.7	62	212	80	273	104	355	135	461	87	0.60	1.55	5.29	170	580	211	720	264	901	330	1126	412	1406	RSCR	/	4	ST	CCC CB CE				
	ADW66HV	1/4-		6.6	75	256	98	334	127	433	165	563	106	0.65	1.55	5.31	206	703	258	880	322	1099	403	1375	504	1720	RSCR	/	4	ST	CCC CB CE				
MX	ADW57HV	1/5-		5.7	65	222	85	290	109	372	140	478	85	0.58	1.65	5.62	172	587	215	726	270	921	342	1167	420	1433	RSCR	E-PTC Starting Relay	/	4	ST	CCC CB CE			
	ADW66HV	1/4-		6.6	78	266	102	348	132	450	170	580	103	0.62	1.65	5.63	210	717	260	887	325	1109	412	1406	510	1740	RSCR	/	4	ST	CCC CB CE				
	ADW77HV	1/4		7.7	88	300	114	389	152	519	190	648	115	0.68	1.65	5.64	236	805	293	1000	366	1249	460	1570	571	1948	RSCR	/	4	ST	CCC CB CE				
	ADW86HV	1/3-		8.6	106	362	136	464	178	607	230	785	139	0.76	1.65	5.65	278	949	347	1184	434	1481	545	1860	678	2313	RSCR	/	4	F	CCC CB CE				
	ADW91HV	1/3-		9.1	110	375	140	478	182	621	235	802	142	0.82	1.65	5.65	283	966	350	1194	439	1498	548	1870	681	2324	RSCR	/	4	F	CCC CB CE				
MQ	ADW91HV	1/3-		9.1	100	341	130	444	169	577	220	751	141	0.85	1.55	5.32	275	938	344	1174	430	1467	537	1832	671	2289	RSCR	E-PTC Starting Relay	/	5	F	CCC CB CE			
	ADW110HV	3/8		11.0	123	420	160	546	208	710	270	921	174	0.95	1.55	5.29	338	1153	422	1440	527	1798	659	2249	824	2811	RSCR	/	5	F	CCC CB CE				
	ADW128HV	3/8+		12.8	146	498	189	645	246	839	320	1092	206	1.20	1.55	5.30	400	1365	500	1706	625	2133	781	2665	977	3334	CSR	编程	80	5	F	CCC CB CE			
	ADW142HV	1/2-	14.2	159	543	207	706	269	918	350	1194	225	1.35	1.55	5.31	438	1494	547	1866	684	2334	855	2917	1068	3644	CSR	编程	80	5	F	CCC CB CE				
	ADW153HV	1/2	15.3	173	590	225	768	292	996	380	1297	245	1.55	1.55	5.29	475	1621	594	2027	742	2532	828	2825	1160	3958	CSR	编程	80	5	F	CCC CB CE				

压缩机技术参数 / COMPRESSOR TECHNICAL DATA

R134a 低背压压缩机 电压110-120V~50/60Hz 普效款

R134a LBP 110-120V~50/60Hz OE

产品系列 Serial	产品型号 Model	马力HP	电压 频率 V/Hz	排量 Displacement (cm ³)	制冷量 Cooling Capacity ASHRAE																		电机类型 Motor type	启动器 Starting Device	启动电容 Starting capacitor (uF)	运行电容 Running capacitor (uF)	冷却方式 Cooling	认证 Certificate							
					-35°C (-31F)			-30°C (-22F)			-25°C (-13F)			测试工况 Test Conditions: -23.3°C (-10F)						-20°C (-4F)		-15°C (5F)							-10°C (10F)		-5°C (23F)		0°C (32F)		
					W	Btu/h		W	Btu/h		W	Btu/h		制冷量 Capacity (W)	制冷量 Capacity (Btu/h)	输入功率 Input Power (W)	电流 Current (A)	COP (W/W)	EER (Btu/Wh)	W	Btu/h	W							Btu/h	W	Btu/h	W	Btu/h	W	Btu/h
L	QD25H11G	1/12	110-120V/50-60Hz	2.5	30	102	38	130	50	171	65	222	59	0.90	1.10	3.76	81	276	102	348	127	433	159	543	198	676	RSIR	PTC Starting Relay	/	/	ST	UL ETL			
	QD30H11G	1/10		3.0	34	116	44	150	58	198	75	256	68	1.10	1.10	3.76	94	321	117	399	147	502	183	624	229	781	RSIR	PTC Starting Relay	/	/	ST	UL			
	QD35H11G	1/9		3.5	41	140	53	181	69	235	90	307	69	1.30	1.30	4.45	113	386	141	481	176	601	220	751	275	938	RSIR	PTC Starting Relay	/	/	ST	UL			
	ADW43T6	1/6		4.3	59	201	77	263	100	341	130	444	100	1.40	1.30	4.44	163	556	203	693	254	867	317	1082	397	1355	RSIR	PTC Starting Relay	/	/	ST	UL			
ML	ADW43T6	1/6		4.3	59	201	77	263	100	341	130	444	100	1.40	1.30	4.44	163	556	203	693	254	867	317	1249	458	1563	RSIR	PTC Starting Relay	/	/	ST	UL			
	ADW51T6	1/5		5.1	68	232	89	304	115	392	150	512	115	1.50	1.30	4.45	188	641	234	798	293	1000	366	1249	458	1665	RSIR	PTC Starting Relay	/	/	ST	UL			
	ADW57T6	1/4		5.7	73	249	95	324	123	420	160	546	123	1.60	1.30	4.44	200	682	250	853	313	1068	391	1334	488	1665	RSIR	PTC Starting Relay	/	/	ST	UL			
MX	ADW66T6	1/4+		6.6	89	304	115	392	150	512	195	665	145	2.20	1.35	4.59	244	833	305	1041	381	1300	476	1624	595	2030	RSIR	PTC Starting Relay	/	/	ST	UL			
	ADW77T6	1/3-		7.7	100	341	130	444	169	577	220	751	165	2.40	1.35	4.55	275	938	344	1174	430	1467	537	1832	671	2289	RSIR	PTC Starting Relay	/	/	ST	UL			
	ADW86T6	1/3		8.6	109	372	142	485	185	631	240	819	178	2.60	1.35	4.60	300	1024	375	1280	469	1600	586	1999	732	2498	RSIR	PTC Starting Relay	/	/	ST	UL			
MQ	ADW86T6	1/3		8.6	109	372	142	485	185	631	240	819	178	3.30	1.35	4.60	325	1109	406	1385	508	1733	635	2167	794	2709	CSIR	Current Starting Relay	161-193	/	F	ETL			
	ADW91T6	3/8-		9.1	118	403	154	525	200	682	260	887	193	3.30	1.35	4.60	325	1109	406	1385	508	1733	635	2167	794	2709	CSIR	Current Starting Relay	161-193	/	F	ETL			
	ADW110T6	3/8	11.0	141	481	183	624	239	815	310	1058	230	3.80	1.35	4.60	388	1324	484	1651	605	2064	757	2583	946	3228	CSIR	Current Starting Relay	161-193	/	F	ETL				
	ADW128T6	1/2-	12.8	166	566	216	737	281	959	365	1245	270	4.30	1.35	4.61	456	1556	570	1945	713	2433	891	3040	1114	3801	CSIR	Current Starting Relay	161-193	/	F	ETL				
	ADW142T6	1/2	14.2	183	624	238	812	309	1054	402	1372	298	4.60	1.35	4.60	503	1716	628	2143	785	2678	981	3347	1227	4187	CSR	Current Starting Relay	161-193	15	F	ETL				
	ADW153T6	1/2+	15.3	205	699	266	908	346	1181	450	1535	334	4.80	1.35	4.60	563	1921	703	2399	879	2999	1099	3750	1373	4685	CSR	Current Starting Relay	161-193	15	F	ETL				

轻型商用制冷压缩机

Light Commercial Refrigeration Compressor

R134a 中/高背压压缩机 电压220-240V~50Hz 普效款

R134a M/HBP 220-240V~50Hz OE

产品系列 Serial	产品型号 Model	马力HP	电压 频率 V/Hz	气缸容积 Displacement(cm ³)	制冷量 Cooling Capacity ASHRAE																电机类型 Motor type	启动继电器 Starting Device	启动电容 Starting capacitor (uF)	运行电容 Running capacitor (uF)	冷却方式 Cooling	认证 Certificate		
					-15°C (-5F)				-10°C (-10F)		-5°C (-23F)		-0°C (-32F)		测试工况 Test Conditions: +7.2°C (45F)												10°C (50F)	
					W	Btu/h	W	Btu/h	W	Btu/h	W	Btu/h	制冷量 Capacity (W)	制冷量 Capacity (Btu/h)	输入功率 Input Power (W)	电流 Current (A)	COP (W/W)	EER (Btu/Wh)	W	But/h								
XL	GQR30TG	1/10	220-240V/50Hz-60Hz	3.0	97	331	125	427	145	495	185	631	245	836	129	0.90	1.90	6.48	275	938	RSIR	PTC/电流 Starting Relay	/	/	F	CCC CB CE		
	GQR35TG	1/9		3.5	135	461	175	597	195	665	265	904	385	1314	185	1.10	2.10	7.10	420	1433	RSIR		/	/	F	CCC CB CE		
	GQR45TG	1/6		4.5	176	601	230	785	280	955	350	1194	450	1535	204	1.20	2.20	7.53	485	1655	RSIR		/	/	F	CCC CB CE		
ML	GQR55TG	1/6+		5.5	188	641	245	836	310	1058	390	1331	525	1791	250	1.30	2.10	7.17	575	1962	RSIR	PTC/电流 Starting Relay	/	/	F	CCC CB CE		
	GQR60TG	1/4		6.5	258	880	335	1143	435	1484	545	1860	665	2269	290	1.70	2.30	7.82	705	2405	RSIR		/	/	F	CCC CB CE		
	GQR70TG	1/4		7.0	285	972	370	1262	480	1638	595	2030	720	2457	340	1.90	2.10	7.23	765	2610	RSIR		/	/	F	CCC CB CE		
MQ	GQR80TG	1/4+		8.3	324	1105	420	1433	550	1877	680	2320	880	3003	391	2.15	2.25	7.68	855	2917	CSR	电流 Starting Relay	80	15	F	CCC CB CE		
	GQR90TG	1/3-		9.5	365	1245	474	1617	621	2119	768	2620	990	3378	440	2.45	2.25	7.68	955	3258	CSR		80	15	F	CCC CB CE		
	GQR11TG	3/8		11.4	412	1406	536	1829	702	2395	868	2962	1180	4026	454	2.20	2.60	8.87	1079	3682	CSR		80	15	F	CCC CB CE		
	GQR12TG	3/8+		12.7	467	1593	606	2068	793	2706	981	3347	1300	4436	500	2.25	2.60	8.87	1208	4122	CSR		80	15	F	CCC CB CE		
	GQR14TG	1/2		14.3	527	1798	685	2337	896	3057	1108	3780	1450	4947	580	2.75	2.50	8.53	1365	4657	CSR		80	15	F	CCC CB CE		
	GQR16TG	1/2+		15.3	580	1979	754	2573	1012	3453	1252	4272	1490	5084	596	2.80	2.50	8.53	1535	5237	CSR		80	15	F	CCC CB CE		
MD (重型)	GQR12TG	1/2		12.1	465	1587	650	2218	850	2900	1034	3528	1270	4333	560	2.60	2.30	7.74	1325	4521	CSIR	电流 Starting Relay	80	/	F	CCC CB CE		
	GQR14TG	5/8		14.3	549	1873	768	2620	912	3112	1124	3835	1432	4886	653	2.80	2.20	7.48	1582	5398	CSIR		80	/	F	CCC CB CE		
	GQR16TG	5/8		16.1	619	2112	865	2951	1015	3463	1205	4111	1524	5200	715	3.00	2.20	7.27	1756	5991	CSR		80	10	F	CCC CB CE		
	GQR19TG	3/4		18.4	660	2252	932	3180	897	3061	1212	4135	1645	5613	774	3.60	2.13	7.25	2249	7674	CSR		80	10	F	CCC CB CE		

轻型商用制冷压缩机

Light Commercial Refrigeration Compressor

R134a 中/高背压压缩机 电压110-120V~60Hz 普效款

R134a M/HBP 110-120V~60Hz OE

产品系列 Serial	产品型号 Model	马力HP	电压 频率 V/Hz	Displacement 气缸排量 (cm ³)	制冷量 Cooling Capacity ASHRAE																电机系列 Motor type	启动器 Starting Device	启动电容 Starting capacitor (uF)	运行电容 Running capacitor (uF)	冷却方式 Cooling	认证 Certificate						
					-15°C (-5F)				-10°C (-10F)				-5°C (-23F)				-0°C (-32F)										测试工况 Test Conditions: +7.2°C (45F)				10°C (50F)	
					W	Btu/h	W	Btu/h	W	Btu/h	W	Btu/h	W	Btu/h	W	Btu/h	制冷量 Capacity (W)	制冷量 Capacity (Btu/h)	输入功率 Input Power (W)	电流 Current (A)							COP (W/W)	EER (Btu/Wh)	W	But/h		
XL	GQR30TD	1/10	110-120V/50Hz-60Hz	3.0	118	403	150	512	174	594	225	768	295	1007	134	1.80	2.20	7.51	340	1160	RSIR	PTC/启动器 PTC/启动器	/	/	F	CCC CB CE						
	GQR35TD	1/9		3.5	162	553	210	717	234	798	320	1092	465	1587	211	2.00	2.20	7.52	504	1720	RSIR		/	/	F	CCC CB CE						
ML	GQR45TD	1/6		4.5	210	717	275	938	340	1160	340	1160	540	1842	245	2.10	2.20	7.52	580	1979	RSIR		/	/	F	CCC CB CE						
	GQR55TD	1/6+		5.5	239	815	310	1058	390	1331	480	1638	610	2081	290	2.50	2.10	7.18	665	2269	RSIR		/	/	F	CCC CB CE						
MX	GQR60TD	1/4		6.5	315	1075	378	1290	510	1740	650	2218	735	2508	320	2.90	2.30	7.84	786	2682	RSIR		/	/	F~	CCC CB CE						
	GQR70TD	1/4		7.0	330	1126	430	1467	545	1860	750	2559	806	2750	385	3.50	2.10	7.14	862	2941	RSIR		/	/	F	CCC CB CE						
MQ	GQR80TD	1/4+		8.0	362	1235	470	1604	625	2133	820	2798	907	3095	415	3.80	2.20	7.46	964	3289	RSIR		/	/	F	CCC CB CE						
	GQR90TD	1/3-		9.1	408	1392	530	1808	772	2371	890	3037	1019	3477	465	4.20	2.20	7.48	1074	3664	CSIR		80	/	F	CCC CB CE						
	GQR11TD	3/8		11.0	462	1576	600	2047	872	2634	954	3255	1100	3753	480	4.40	2.30	7.82	1155	3941	CSIR		80	/	F	CCC CB CE						
MD (重型)	GQR12TD	3/8+		12.8	522	1781	678	2313	872	2975	1034	3528	1270	4333	580	5.20	2.20	7.47	1325	4521	CSIR		80	/	F	CCC CB CE						
	GQR12TD	3/8+		12.8	522	1781	678	2313	985	2975	1034	3528	1270	4333	580	5.20	2.20	7.47	1325	4521	CSR		80	10	F	CCC CB CE						
	GQR14TD	1/2		14.2	583	1989	758	2586	1113	3361	1218	4156	1402	4784	610	5.50	2.30	7.84	1457	4971	CSR		80	10	F	CCC CB CE						
	GQR16TD	1/2+		15.3	638	2177	829	2829	1218	3798	1375	4692	1641	5599	720	5.80	2.30	7.78	1696	5787	CSR		80	10	F	CCC CB CE						

除湿机专用压缩机

Compressor specialized for Dehumidifier

R134a 中/高背压压缩机 电压220-240V~50Hz

R134a M/HBP 220-240V~50Hz

产品系列 Serial	产品型号 Model	马力HP	电压 频率 V/Hz	排量 Displacement (cm ³)	制冷量 Cooling Capacity ASHRAE														电机类型 Motor type	启动器 Starting Device	启动电容 Starting capacitor (uF)	运行电容 Running capacitor (uF)	冷却方式 Cooling	认证 Certificate								
					-15°C (-5F)				-10°C (-10F)				-5°C (-23F)				-0°C (-32F)								测试工况 Test Conditions: +7.2°C (45F)							
					W		Btu/h		W		Btu/h		W		Btu/h		W								Btu/h		制冷量 Capacity (W)	制冷量 Capacity (Btu/h)	输入功率 Input Power (W)	电流 Current (A)	COP (W/W)	EER (Btu/Wh)
XL	GQR30TC	1/10	220-240V/50-60Hz	3.0	97	331	125	427	145	495	185	631	245	836	129	0.9	1.9	6.48	275	938	RSIR	电容	/	/	F	CCC						
	GQR35TC	1/9		3.5	135	461	175	597	195	665	265	904	385	1314	185	1.1	2.1	7.17	420	1433	RSIR	PTC/电容	/	/	F	CCC						
	GQR45TC	1/6		4.5	176	601	230	785	280	955	350	1194	450	1535	204	1.2	2.2	7.51	485	1655	RSIR	启动器	/	/	F	CCC						
ML	GQR55TC	1/6+		5.5	245	836	310	1058	390	1331	525	1791	575	1962	273	1.5	2.1	7.19	615	2098	RSIR	启动器	/	/	F	CCC						
	GQR60TC	1/4		6.5	335	1143	435	1484	545	1860	665	2269	705	2405	306	1.9	2.3	7.86	745	2542	RSIR	启动器	/	/	F	CCC						
	GQR70TC	1/4		7.0	370	1262	480	1638	595	2030	720	2457	765	2610	364	2.1	2.1	7.17	805	2747	RSIR	启动器	/	/	F	CCC						
MQ	GQR80TC	1/4+		8.0	420	1433	550	1877	680	2320	810	2764	855	2917	388	2.2	2.2	7.52	895	3054	CSIR	启动器	80	/	F	CCC						
	GQR90TC	1/3-		9.0	474	1617	621	2119	768	2620	910	3105	955	3258	434	2.3	2.2	7.51	995	3395	CSIR	启动器	80	/	F	CCC						
	GQR11TC	3/8		11.0	536	1829	702	2395	868	2962	1034	3528	1079	3682	469	2.9	2.3	7.85	1119	3818	CSIR	启动器	80	/	F	CCC						
MD	GQR12TC	3/8+		12.0	606	2068	793	2706	981	3347	1168	3985	1208	4122	549	3.4	2.2	7.51	1248	4258	CSIR	启动器	80	/	F	CCC						
	GQR14TC	1/2		14.0	685	2337	896	3057	1108	3780	1320	4504	1365	4657	593	3.6	2.3	7.85	1305	4453	CSIR	启动器	80	/	F	CCC						
	GQR16TC	1/2+		16.0	754	2573	1012	3453	1252	4272	1492	5091	1535	5237	667	4.0	2.3	7.85	1575	5374	CSIR	启动器	80	/	F	CCC						

R134a 中/高背压压缩机 电压110-120V~60Hz

R134a M/HBP 110-120V~60Hz

产品系列 Serial	产品型号 Model	马力HP	电压 频率 V/Hz	排量 Displacement (cm ³)	制冷量 Cooling Capacity ASHRAE														电机类型 Motor type	启动器 Starting Device	启动电容 Starting capacitor (uF)	运行电容 Running capacitor (uF)	冷却方式 Cooling	认证 Certificate								
					-15°C (-5F)				-10°C (-10F)				-5°C (-23F)				-0°C (-32F)								测试工况 Test Conditions: +7.2°C (45F)							
					W		Btu/h		W		Btu/h		W		Btu/h		W								Btu/h		制冷量 Capacity (W)	制冷量 Capacity (Btu/h)	输入功率 Input Power (W)	电流 Current (A)	COP (W/W)	EER (Btu/Wh)
XL	GQR30TCD	1/10	110-120V/50-60Hz	3.0	118	403	150	512	174	594	225	768	295	1007	134	1.8	2.2	7.51	340	1160	RSIR	启动器	/	/	F	CCC						
	GQR35TCD	1/9		3.5	162	553	210	717	234	798	320	1092	465	1587	211	2.0	2.2	7.52	504	1720	RSIR	启动器	/	/	F	CCC						
	GQR45TCD	1/6		4.5	210	717	275	938	340	1160	420	1433	540	1842	245	2.1	2.2	7.52	580	1979	RSIR	启动器	/	/	F	CCC						
ML	GQR55TCD	1/6+		5.5	310	1058	390	1331	480	1638	610	2081	665	2269	316	2.9	2.1	7.18	720	2457	RSIR	启动器	/	/	F	CCC						
	GQR60TCD	1/4		6.5	378	1290	510	1740	650	2218	731	2494	786	2682	341	3.5	2.3	7.86	841	2869	RSIR	启动器	/	/	F	CCC						
	GQR70TCD	1/4		7.0	430	1467	545	1860	750	2559	806	2750	862	2941	410	3.8	2.1	7.17	917	3129	RSIR	启动器	/	/	F	CCC						
MQ	GQR80TCD	1/4+		8.0	470	1604	625	2133	820	2798	907	3095	964	3289	438	4.2	2.2	7.51	1019	3477	CSIR	启动器	93-169	/	F	CCC						
	GQR90TCD	1/3-		9.1	530	1808	695	2371	890	3037	1019	3477	1074	3664	488	3.8	2.2	7.51	1129	3852	CSIR	启动器	93-169	/	F	CCC						
	GQR11TCD	3/8		11.0	600	2047	772	2634	954	3255	1100	3753	1155	3941	502	5.2	2.3	7.85	1210	4129	CSIR	启动器	93-169	/	F	CCC						
MD	GQR12TCD	3/8+		12.8	678	2313	872	2975	1034	3528	1270	4333	1325	4521	602	5.5	2.2	7.51	1380	4709	CSIR	启动器	93-169	/	F	CCC						
	GQR14TCD	1/2		14.2	758	2586	985	3361	1218	4156	1402	4784	1457	4971	633	5.8	2.3	7.85	1512	5159	CSIR	启动器	93-169	/	F	CCC						
	GQR16TCD	1/2+		15.3	829	2829	1113	3798	1375	4692	1641	5599	1696	5787	737	6.0	2.3	7.85	1751	5974	CSIR	启动器	93-169	/	F	CCC						

制冰机专用

Compressor specialized for Ice-maker

R134a 中/高背压压缩机 电压220-240V~50Hz

R134a M/HBP 220-240V~50Hz

产品系列 Serial	产品型号 Model	马力HP	电压 频率 V/Hz	气缸容积 Displacement(cm ³)	制冷量 Cooling Capacity ASHRAE														电机类型 Motor type	启动器 Starting Device	启动电容 Starting capacitor (uF)	运行电容 Running capacitor (uF)	冷却方式 Cooling	认证 Certificate
					-15°C (-5F)		-10°C (-10F)		测试工况 Test Conditions: -6.7°C (20F)						-5°C (23F)		0°C (32F)							
					W	Btu/h	W	Btu/h	制冷量 Capacity (W)	制冷量 Capacity (Btu/h)	输入功率 Input Power (W)	电流 Current (A)	COP (W/W)	EER (Btu/Wh)	W	But/h	W	But/h						
XL	GQR30TZ	1/10	220-240V/50Hz	3.0	112	382	145	495	165	563	116	0.78	1.42	4.85	185	631	230	785	RSIR	PTC/启动器 Relay	/	/	F	CCC
	GQR35TZ	1/9		3.5	136	464	164	560	195	665	137	0.85	1.42	4.86	215	734	265	904	RSIR		/	/	F	CCC
	GQR45TZ	1/6		4.5	177	604	230	785	265	904	140	0.97	1.89	6.46	280	955	350	1194	RSIR		/	/	F	CCC
ML	GQR55TZ	1/6+		5.5	188	641	245	836	297	1013	160	1.05	1.85	6.33	310	1058	390	1331	RSIR		/	/	F	CCC
	GQR60TZ	1/4		6.5	258	880	335	1143	410	1399	207	1.44	1.98	6.76	435	1484	545	1860	RSIR		/	/	F	CCC
	GQR70TZ	1/4		7.0	285	972	370	1262	455	1552	206	1.45	2.2	7.54	480	1638	595	2030	RSIR		/	/	F	CCC
MX	GQR80TZ	1/4+		8.0	324	1105	420	1433	520	1774	232	1.54	2.2	7.65	550	1877	680	2320	RSIR		/	/	F	CCC
	GQR90TZ	1/3-		9.1	365	1245	474	1617	595	2030	267	1.83	2.2	7.60	621	2119	768	2620	RSIR		/	/	F	CCC
	GQR80TZ	1/4+		8.0	324	1105	420	1433	520	1774	248	1.95	2.1	7.15	550	1877	680	2320	CSIR		80	/	F	CCC
MQ	GQR90TZ	1/3-		9.1	365	1245	474	1617	595	2030	285	2.23	2.08	7.12	621	2119	768	2620	CSIR	80	/	F	CCC	
	GQR11TZ	3/8		11.0	412	1406	536	1829	680	2320	360	2.60	1.89	6.44	702	2395	868	2962	CSIR	80	/	F	CCC	
	GQR12TZ	3/8+		12.8	467	1593	606	2068	765	2610	394	2.67	1.94	6.62	793	2706	981	3347	CSIR	80	/	F	CCC	
	GQR14TZ	1/2		14.2	527	1798	685	2337	845	2883	435	2.82	1.94	6.63	896	3057	1108	3780	CSIR	80	/	F	CCC	
MD	GQR14TZ	1/2		14.2	527	1798	685	2337	845	2883	435	2.82	1.94	6.63	896	3057	1108	3780	CSR	80	10	F	CCC	
	GQR16TZ	1/2+		15.3	580	1979	754	2573	960	3276	490	3.24	1.96	6.68	1012	3453	1252	4272	CSR	80	10	F	CCC	

R134a 中/高背压压缩机 电压110-120V~60Hz

R134a M/HBP 110-120V~60Hz

产品系列 Serial	产品型号 Model	马力HP	电压 频率 V/Hz	气缸容积 Displacement(cm ³)	制冷量 Cooling Capacity ASHRAE														电机类型 Motor type	启动器 Starting Device	启动电容 Starting capacitor (uF)	运行电容 Running capacitor (uF)	冷却方式 Cooling	认证 Certificate
					-15°C (-5F)		-10°C (-10F)		测试工况 Test Conditions: -6.7°C (20F)						-5°C (23F)		0°C (32F)							
					W	Btu/h	W	Btu/h	制冷量 Capacity (W)	制冷量 Capacity (Btu/h)	输入功率 Input Power (W)	电流 Current (A)	COP (W/W)	EER (Btu/Wh)	W	But/h	W	But/h						
XL	GQR30TZD	1/10	110-120V/50Hz	3.0	118	403	155	529	176	601	123	1.5	1.42	4.88	185	631	230	785	RSIR	PTC/启动器 Relay	/	/	F	CCC
	GQR35TZD	1/9		3.5	162	553	164	560	195	665	137	1.7	1.42	4.86	215	734	265	904	RSIR		/	/	F	CCC
	GQR45TZD	1/6		4.5	210	717	230	785	265	904	140	1.9	1.89	6.46	280	955	350	1194	RSIR		/	/	F	CCC
ML	GQR55TZD	1/6+		5.5	310	1058	245	836	297	1013	160	2.05	1.85	6.33	310	1058	390	1331	RSIR		/	/	F	CCC
	GQR60TZD	1/4		6.5	378	1290	335	1143	410	1399	207	2.2	1.98	6.76	435	1484	545	1860	RSIR		/	/	F	CCC
	GQR70TZD	1/4		7.0	430	1467	370	1262	455	1552	206	2.4	2.2	7.54	480	1638	595	2030	RSIR		/	/	F	CCC
MX	GQR80TZD	1/4+		8.0	470	1604	420	1433	520	1774	232	2.5	2.2	7.65	550	1877	680	2320	RSIR		/	/	F	CCC
	GQR90TZD	1/3-		9.1	530	1808	474	1617	595	2030	267	2.6	2.2	7.60	621	2119	768	2620	RSIR		/	/	F	CCC
	GQR80TZD	1/4+		8.0	470	1604	420	1433	520	1774	248	2.5	2.1	7.15	550	1877	680	2320	CSIR		93-169	/	F	CCC
MQ	GQR90TZD	1/3-		9.1	530	1808	474	1617	595	2030	285	2.6	2.08	7.12	621	2119	768	2620	CSIR	93-169	/	F	CCC	
	GQR11TZD	3/8		11.0	600	2047	536	1829	680	2320	360	2.8	1.89	6.44	702	2395	868	2962	CSIR	93-169	/	F	CCC	
	GQR12TZD	3/8+		12.8	678	2313	606	2068	765	2610	394	3.0	1.94	6.62	793	2706	981	3347	CSIR	93-169	/	F	CCC	
	GQR14TZD	1/2		14.2	758	2586	685	2337	845	2883	435	3.2	1.94	6.63	896	3057	1108	3780	CSR	93-169	25	F	CCC	
MD	GQR16TZD	1/2+		15.3	829	2829	754	2573	960	3276	490	3.4	1.96	6.68	1012	3453	1252	4272	CSR	93-169	25	F	CCC	

压缩机技术参数 / COMPRESSOR TECHNICAL DATA

R290 中/低背压压缩机 电压220-240V~50Hz 普效型

R290 L/MBP 220-240V~50Hz OE

产品系列 Serial	产品型号 Model	马力HP	电压 频率 V/Hz	排气容积 Displacement(cm³)	制冷量 Cooling Capacity ASHRAE																电机类型 Motor Type	启动器 Starting Device	启动电容 Starting capacitor (uF)	运行电容 Running capacitor (uF)	冷却方式 Cooling	认证 Certificate											
					-40°C (-31F)				-35°C (-22F)				-30°C (-13F)				-25°C (-13F)										测试工况Test Conditions: -23.3°C (-10F)					-20°C (-4F)		-15°C (5F)	-10°C (10F)	-5°C (23F)	0°C (32F)
					W	Btu/h	W	Btu/h	W	Btu/h	W	Btu/h	W	Btu/h	W	Btu/h	制冷量 Capacity (W)	制冷量 Capacity (Btu/h)	输入功率 Input Power (W)	电流 Current (A)							COP (W/W)	EER (Btu/Wh)	W	W	W	W	W				
XL	GQR30U	1/12+	220-240V/50Hz	3.0	33	113	65	222	97	331	123	420	80	450	101	0.7	1.30	4.46	158	185	235	299	379	RSIR	PTC	/	/	ST	CCC								
ML	GQR45U	1/5		4.5	85	290	112	382	145	495	184	628	208	710	143	0.9	1.45	4.96	230	283	345	421	513	RSIR	PTC	/	/	ST	CCC								
	GQR55U	1/4		5.5	110	375	145	495	188	641	238	812	230	904	183	1.2	1.45	4.94	297	364	440	532	643	RSIR	PTC	/	/	ST	CCC								
MX	GQR60U	1/3		6.5	137	467	180	614	233	795	295	1007	280	1160	234	1.3	1.45	4.96	367	450	543	655	791	CSIR	重锤	50	/	ST	CCC								
	GQR70U	1/3		7.0	154	525	197	672	265	904	327	1116	320	1269	256	1.4	1.45	4.96	399	482	575	686	818	CSIR	重锤	50	/	ST	CCC								
MQ	GQR80U	1/3+		8.0	184	628	227	775	302	1030	364	1242	360	1433	289	1.7	1.45	4.96	455	538	635	749	885	CSIR	重锤	50	/	ST	CCC								
	GQR80U	1/3+		8.0	184	628	227	775	302	1030	364	1242	400	1433	289	1.7	1.45	4.96	455	538	635	749	885	CSIR	重锤	50	/	F	CCC								
	GQR90U	1/2-		9.0	210	717	253	863	328	1119	390	1331	450	1535	310	1.9	1.45	4.95	485	568	685	826	996	CSIR	重锤	50	/	F	CCC								
	GQR11U	1/2		11.0	245	836	288	983	363	1239	425	1450	500	1740	351	2.0	1.45	4.96	540	623	740	879	1044	CSIR	重锤	50	/	F	CCC								
MD	GQR12U	1/2+		12.0	275	938	325	1109	405	1382	475	1621	550	1979	399	2.6	1.45	4.96	605	688	805	942	1102	CSIR	重锤	50	/	F	CCC								
	GQR14U	3/4		14.3	296	1010	350	1194	460	1570	600	2047	650	2218	448	3.0	1.45	5.00	753	935	1130	1266	1482	CSIR	重锤	50	/	F	CCC								
	GQR14U	3/4		14.3	296	1010	350	1194	460	1570	600	2047	650	2218	500	3.3	1.30	4.44	753	935	1130	1266	1482	CSR	重锤	80	10	F	CCC								
	GQR16U	3/4		16.2	330	1057	417	1426	530	1808	686	2341	740	2525	569	3.5	1.30	4.44	855	1055	1290	1320	1520	CSR	重锤	80	10	F	CCC								
	GQR19U	4/5		19.0	400	1364	500	1706	660	2252	850	2900	790	3327	750	3.8	1.30	4.44	1100	1250	1420	1580	1730	CSR	重锤	80	10	F	CCC								

R290 中/高背压压缩机 电压220-240V~50Hz 普效型

R290 M/HBP 220-240V~50Hz OE

产品系列 Serial	产品型号 Model	马力HP	电压 频率 V/Hz	排气容积 Displacement(cm³)	制冷量 Cooling Capacity ASHRAE											电机类型 Motor type	启动器 Starting Device	启动电容 Starting capacitor (uF)	运行电容 Running capacitor (uF)	冷却方式 Cooling	认证 Certificate			
					-15°C (5F)		-10°C (-22F)		-5°C (-23F)		0°C (23F)		测试工况Test Conditions: 7.2°C (45F)											
					W	Btu/h	W	Btu/h	W	Btu/h	W	Btu/h	制冷量 Capacity (W)	制冷量 Capacity (Btu/h)	输入功率 Input Power (W)							电流 Current (A)	COP (W/W)	EER (Btu/Wh)
L	GQR30U G	1/9-	220-240V/50Hz	3.0	140	478	180	614	220	751	305	1041	420	1433	162	0.80	2.60	8.87	RSIR	PTC	/	/	F	CCC
ML	GQR45U G	1/6		4.5	210	717	275	938	340	1160	450	1535	540	1842	216	1.25	2.50	8.53	RSIR	PTC	/	/	F	CCC
	GQR55U G	1/5		5.5	285	972	350	1194	460	1570	560	1911	680	2320	272	1.55	2.50	8.53	RSIR	PTC	/	/	F	CCC
MX	GQR60U G	1/4		6.0	340	1160	445	1518	580	1979	790	2695	840	2866	323	1.75	2.60	8.87	RSIR	PTC	/	/	F	CCC
	GQR70U G	1/3-		7.0	400	1365	520	1774	685	2337	880	3003	1000	3412	455	2.40	2.20	7.51	RSIR	PTC	/	/	F	CCC
MQ	GQR80U G	3/8		8.0	500	1706	640	2184	810	2764	995	3395	1150	3924	418	2.40	2.75	9.38	CSIR	重锤 Current Starting Replay	50	/	F	CCC
	GQR90U G	3/8+	9.0	530	1808	688	2347	882	3009	1056	3603	1280	4367	492	2.70	2.60	8.87	CSIR	重锤 Current Starting Replay	50	/	F	CCC	

压缩机技术参数 / COMPRESSOR TECHNICAL DATA

R404a 中/低背压压缩机 电压220-240V~50Hz 普效型

R404a L/MBP 220-240V~50Hz OE

产品系列 Serial	产品型号 Model	马力HP	电压 频率 V/Hz	排量 Displacement(cm ³)	制冷量 Cooling Capacity ASHRAE																	电机类型 Motor Type	启动器 Starting Device	启动电容 Starting capacitor (uF)	运行电容 Running capacitor (uF)	冷却方式 Cooling	认证 Certificate									
					-40°C (-31F)				-35°C (-22F)				-30°C (-13F)				-25°C (-13F)				测试工况Test Conditions: -23.3°C (-10F)							-20°C (-4F)	-15°C (5F)	-10°C (10F)	-5°C (23F)	0°C (32F)				
					W	Btu/h	W	Btu/h	W	Btu/h	W	Btu/h	W	Btu/h	W	Btu/h	制冷量 Capacity (W)	制冷量 Capacity (Btu/h)	输入功率 Input Power (W)	电流 Current (A)	COP (W/W)							EER (Btu/Wh)	W	W	W	W	W			
ML	GQR45K	1/5	220-240V/50Hz	4.5	95	324	135	461	165	563	215	734	244	833	168	1.2	1.45	4.95	275	355	425	549	708	RSIR	PTC/重锤 Relay	/	/	ST	CCC							
	GQR55K	1/4		5.5	125	427	165	563	210	717	265	904	305	1041	182	1.4	1.45	4.95	330	410	495	615	764	RSIR		/	/	ST	CCC							
MX	GQR60K	1/3		6.5	145	495	185	631	238	812	312	1065	365	1245	251	1.5	1.45	4.95	435	520	625	747	893	RSIR		/	/	ST	CCC							
MQ	GQR70K	1/3		7.0	155	529	205	699	265	904	358	1221	395	1348	272	1.7	1.45	4.95	475	570	675	810	972	CSIR		50	/	ST	CCC							
	GQR80K	1/3+		8.0	175	597	225	768	315	1075	407	1389	465	1587	320	1.8	1.45	4.95	565	675	785	938	1120	CSIR		50	/	ST	CCC							
	GQR90K	1/2-		9.0	205	699	255	870	356	1215	445	1518	515	1757	355	1.9	1.45	4.95	625	735	855	1005	1182	CSIR		50	/	ST	CCC							
MD	GQR11K	1/2		11.0	245	836	295	1007	395	1348	485	1655	565	1928	389	2.2	1.45	4.95	685	795	905	1050	1219	CSIR		Current Starting Relay	50	/	F	CCC						
	GQR12K	3/4		12.1	275	938	325	1109	425	1450	545	1860	640	2184	474	3.5	1.35	4.60	715	833	995	1120	1327	CSIR			80	/	F	CCC						
	GQR14K	3/4		14.3	315	1075	375	1280	495	1689	655	2235	750	2559	550	3.5	1.35	4.60	815	995	1150	1290	1585	CSR			80	10	F	CCC						
	GQR16K	4/5		16.2	345	1177	445	1518	585	1996	755	2576	850	2900	645	4.5	1.35	4.60	965	1033	1230	1353	1676	CSR			80	10	F	CCC						
	GQR19K	7/8	19.0	420	1433	510	1740	650	2218	800	2730	920	3139	718	4.5	1.35	4.60	1085	1130	1350	1480	1830	CSR	80	10	F	CCC									

R404a 中/高背压压缩机 电压220-240V~50Hz 普效型

R404a M/HBP 220-240V~50Hz OE

产品系列 Serial	产品型号 Model	马力HP	电压 频率 V/Hz	排量 Displacement(cm ³)	制冷量 Cooling Capacity ASHRAE												电机类型 Motor type	启动器 Starting Device	启动电容 Starting capacitor (uF)	运行电容 Running capacitor (uF)	冷却方式 Cooling	认证 Certificate		
					-15°C (-31F)		-10°C (-22F)		-5°C (-13F)		0°C (-13F)		测试工况Test Conditions: 7.2°C(45F)											
					W	Btu/h	W	Btu/h	W	Btu/h	W	Btu/h	制冷量 Capacity (W)	制冷量 Capacity (Btu/h)	输入功率 Input Power (W)	电流 Current (A)							COP (W/W)	EER (Btu/Wh)
MD	GQR12K G	1/2+	220-240V/50Hz	12.1	833	2839	862	2938	1080	3681	1327	4522	1895	6466	861	4.15	2.20	7.37	CSR	重锤 Current Starting Relay	80	10	F	CCC
	GQR14K G	1/2+		14.3	995	3391	1030	3510	1290	4397	1585	5402	2180	7438	991	5.2	2.20	7.37	CSR		80	10	F	CCC
	GQR16K G	3/4		16.2	1033	3524	1068	3644	1353	4616	1676	5718	2390	8155	1086	6.4	2.20	7.37	CSR		80	10	F	CCC

变频系列压缩机 / Frequency Conversion Series Compressors

R600a LBP 220V/50Hz

产品系列 Serial	产品型号 Model	电压 频率 V/Hz	排量 Displacement(cm ³)	转速 Rotate Speed	测试工况Test Conditions: -23.3°C(-10F)			电机类型 Motor type	启动器 Starting Device	冷却方式 Cooling	认证 Certificate	
					制冷量 Capacity (W)	制冷量 Capacity (Btu/h)	COP (W/W)					
VFC	VFC70YV	220V/50Hz	7.0	1600	65	222	1.8	BLDC	驱动装置 Variable frequency drive	ST	CCC	
				2000	86	293	1.85					
				3000	120	409	1.8					
				3500	135	461	1.75					
				4200	175	597	1.7					
	VFC85YV			8.5	1600	88	300					1.8
					2000	110	375					1.85
					3000	160	546					1.8
					3500	175	597					1.75
					4200	220	751					1.7
	VFC91YV			9.0	1600	98	334					1.8
					2000	125	427					1.85
					3000	175	597					1.8
					3500	195	665					1.75
					4200	235	802					1.7
	VFC110YV			11.0	1600	108	368					1.8
					2000	130	444					1.85
					3000	195	665					1.8
					3500	218	744					1.75
					4200	270	921					1.7

R134a LBP 220V/50Hz

产品系列 Serial	产品型号 Model	电压 频率 V/Hz	排量 Displacement(cm ³)	转速 Rotate Speed	测试工况Test Conditions: -23.3°C(-10F)			电机类型 Motor type	启动器 Starting Device	冷却方式 Cooling	认证 Certificate	
					制冷量 Capacity (W)	制冷量 Capacity (Btu/h)	COP (W/W)					
VFC	VFC57HV	220V/50Hz	5.7	1600	88	300	1.67	BLDC	驱动装置 Variable frequency drive	ST	CCC	
				2000	110	375	1.7					
				3000	160	546	1.74					
				3500	175	597	1.75					
				4200	220	751	1.7					
	VFC75HV			7.5	1600	98	334					1.67
					2000	125	427					1.7
					3000	195	665					1.74
					3500	235	802					1.75
					4200	265	904					1.7
	VFC80HV			8.0	1600	108	368					1.67
					2000	195	665					1.7
					3000	236	805					1.74
					3500	270	921					1.75
					4200	285	972					1.7

COMPRESSOR DIMENSIONS 压缩机外型尺寸

DC-L

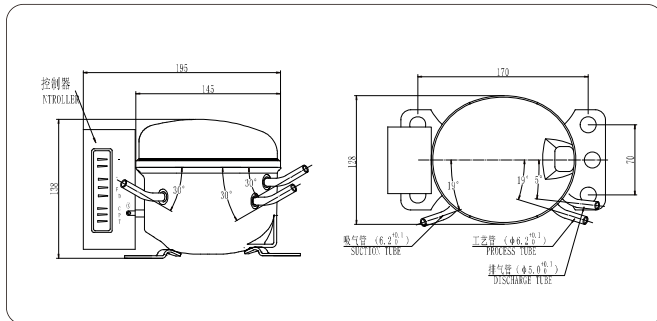

DC-MK

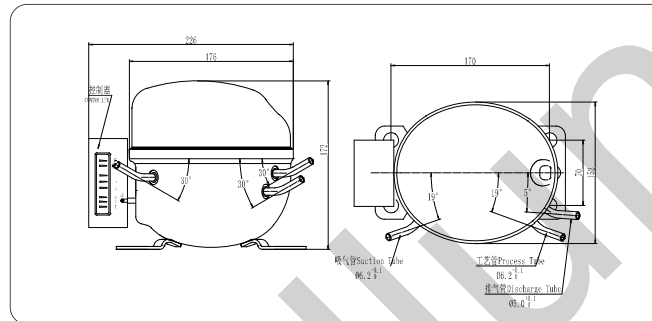

L

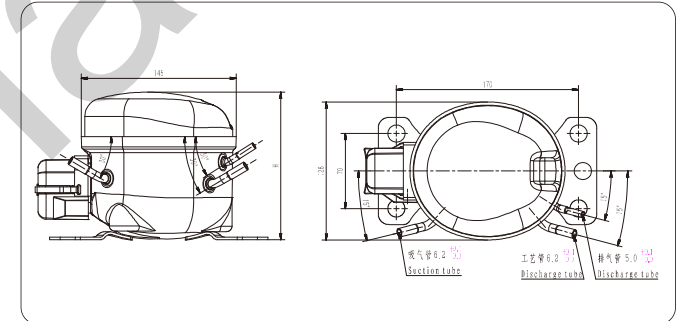

ML

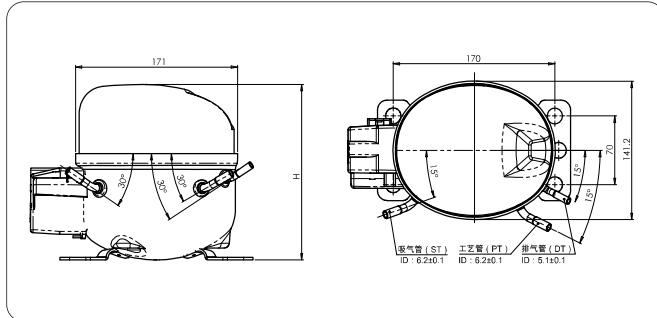

MX

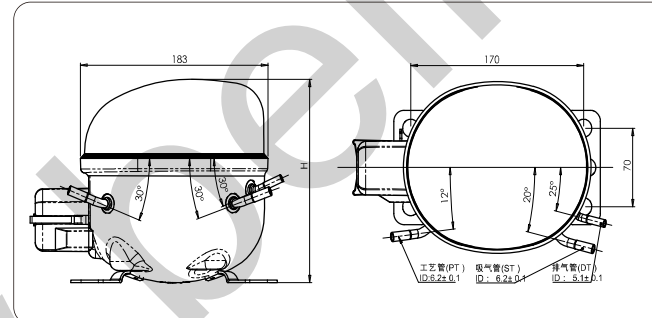

MQ

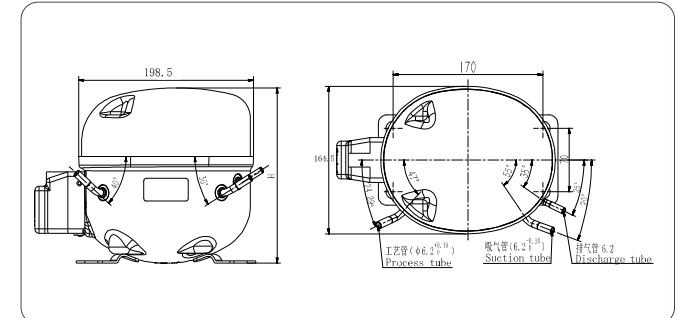

GQR

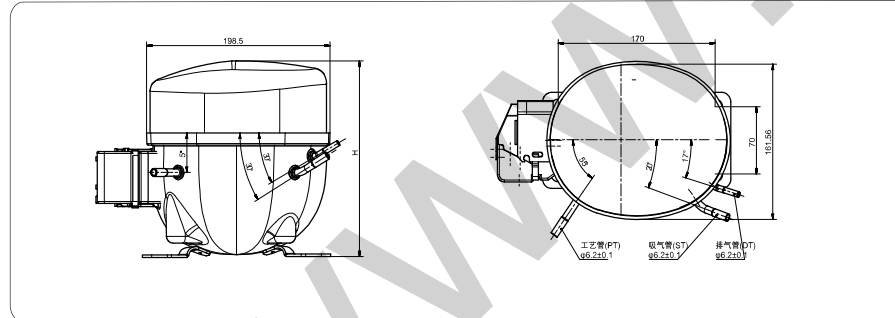

MD

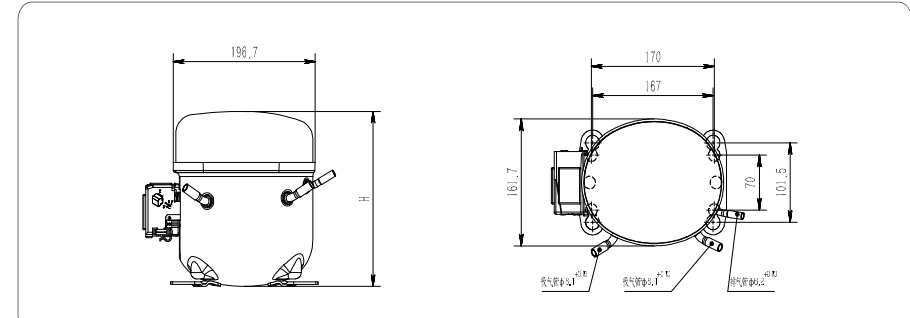

压缩机安装图、电气接线图

COMPRESSOR MOUNTING, ELECTRICAL WIRING DIAGRAM

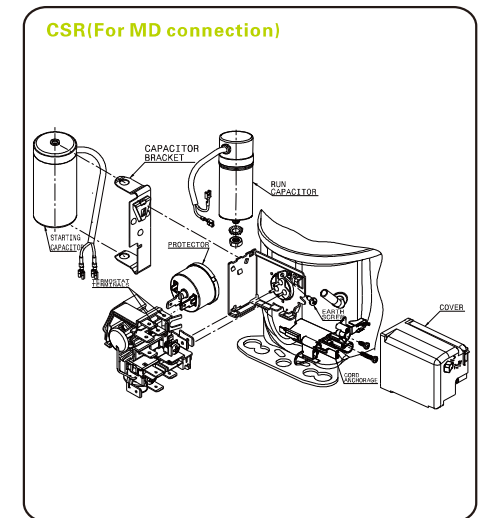
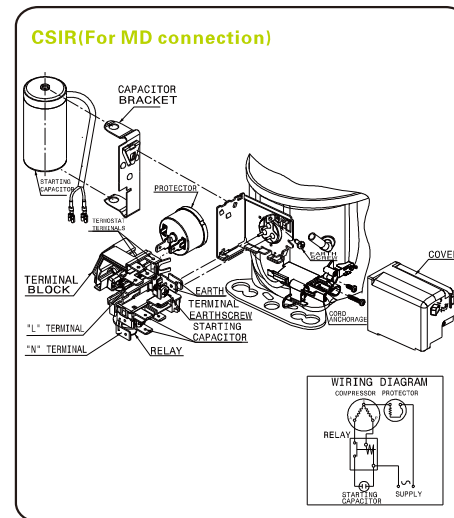
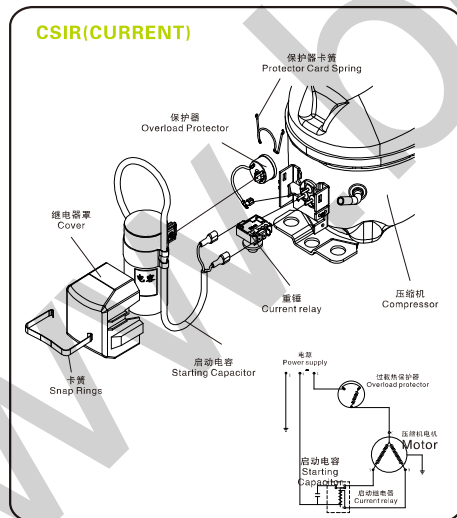
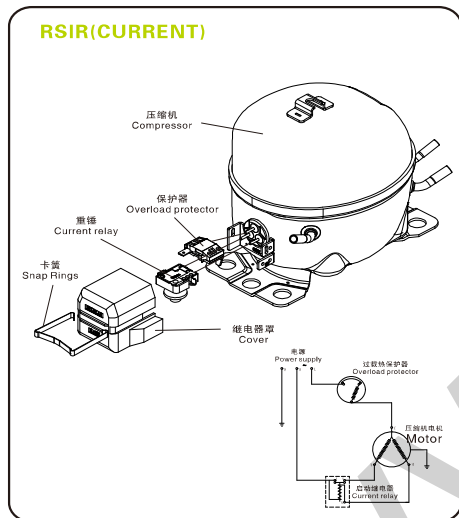
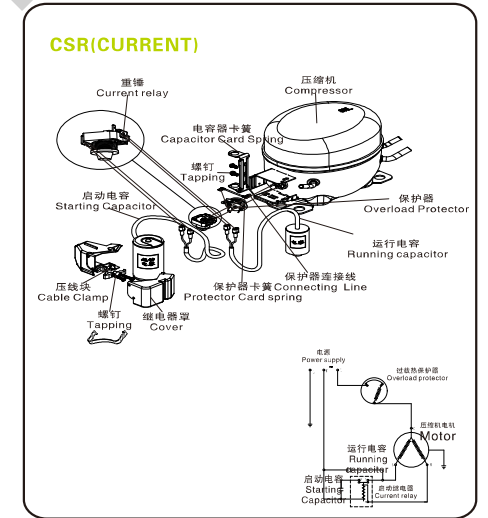
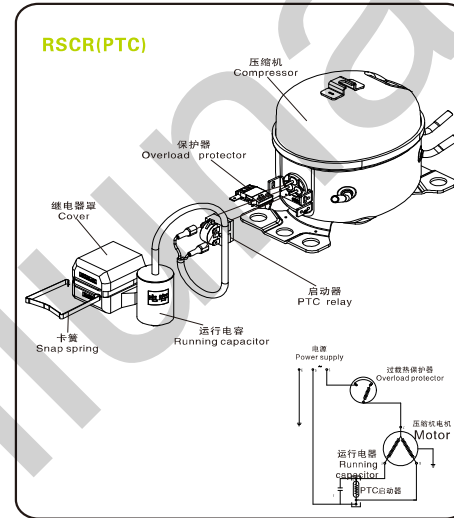
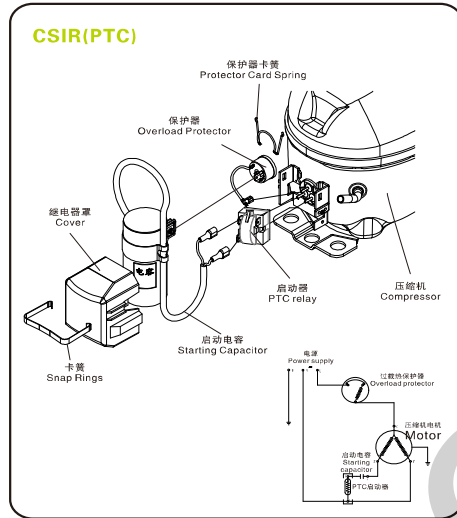
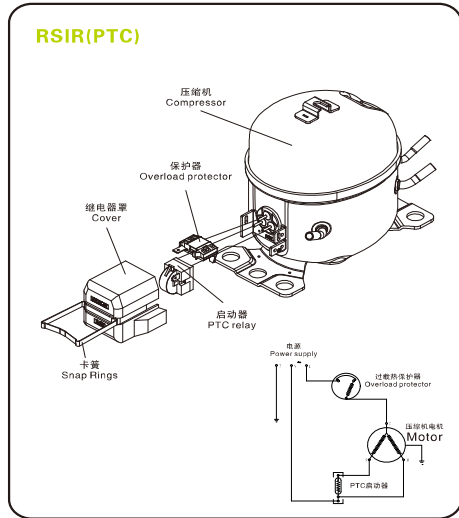

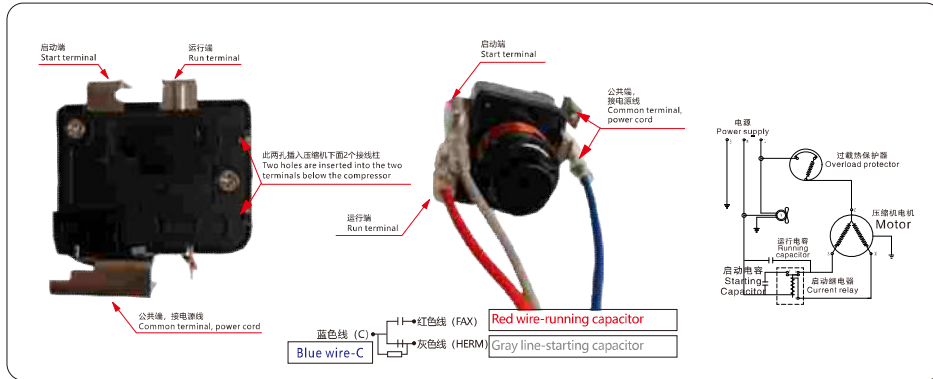

纸箱、木托包装数据 PACKING DETAILS FOR CARTON & PLYWOOD PALLET

纸箱尺寸 Carton Size L x W x H (cm)	木托尺寸 Pallet Size L x W x H (cm)	每托数量 QTY/PLT (PCS)	台 x 层 PCS x layers	20'GP装箱数量 20'GP QTY (PCS)	
				托数 Pallets	总数量 Total QTY (PCS)
26 x 16 x 16	114 x 87 x 110	120	20 x 6	12	2640
	114 x 87 x 90	100	20 x 5	12	
26 x 16 x 19	114 x 87 x 110	100	20 x 5	12	2160
	114 x 87 x 90	80	20 x 4	12	
26 x 16 x 19	114 x 87 x 110	100	20 x 5	12	2160
	114 x 87 x 90	80	20 x 4	12	
26 x 16 x 19	114 x 87 x 110	100	20 x 5	12	2160
	114 x 87 x 90	80	20 x 4	12	
36 x 21 x 24	114 x 90 x 106	48	12 x 4	12	1008
	114 x 90 x 82	36	12 x 3	12	

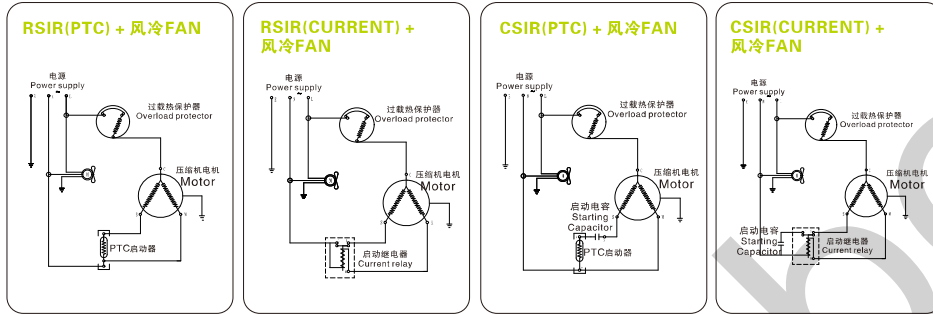
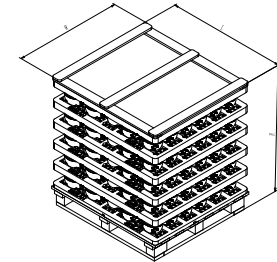
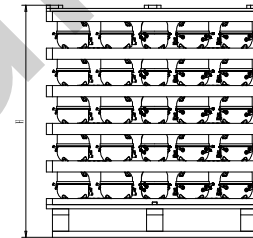

泡沫薄膜缠绕包装数据 PACKING DETAILS FOR FOAM PALLET

托盘尺寸 Pallet Size L x W x H (cm)	每托数量 QTY/PLT (PCS)	台 x 层 PCS x layers	20'GP装箱数量 20'GP QTY (PCS)	
			托数 Pallets	总数量 Total QTY (PCS)
106 x 95 x 118	168	28 x 6	10	3080
106 x 95 x 102	140	28 x 5	10	
114 x 95 x 120	144	24 x 6	10	
114 x 95 x 102	120	24 x 5	10	2640
114 x 95 x 112	120	24 x 5	20	
114 x 95 x 126	120	24 x 5	0	2400
114 x 95 x 103	96	24 x 4	20	
114 x 95 x 130	120	24 x 5	0	1920
114 x 95 x 108	96	24 x 4	20	

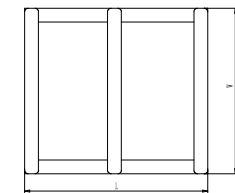
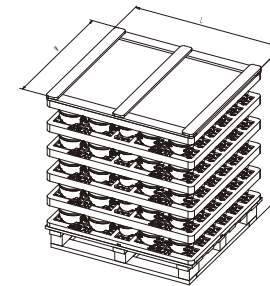

MOUNTING BRACKET

机脚安装图

螺栓式 SCREW TYPE

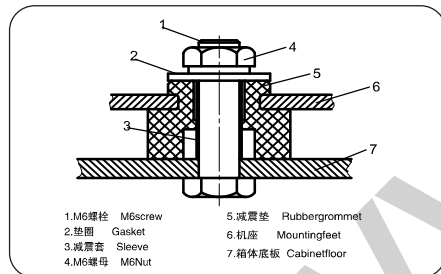

卡扣式 CLAMP TYPE

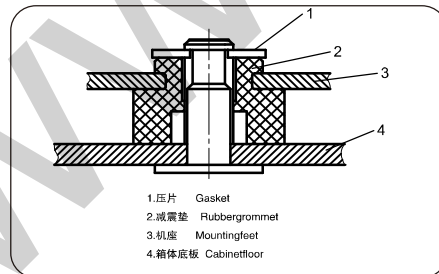

GENERAL REQUIREMENTS

产品通用要求

1. 压缩机应储藏于干燥通风的场所。
2. 压缩机存放、运输时不得倾斜或倒置，同时避免撞击，安装水平与工作状态倾斜不大于5°。
3. 压缩机安装前切勿将橡胶塞拔掉，以免杂物和潮气进入，安装时压缩机胶塞的拔出顺序为排气管、工艺管、吸气管，拔出橡胶塞后应在10分钟内安装完毕。
4. 压缩机的接地装置应永久可靠地与制冷器具连接。
5. 为保持系统压力平衡，压缩机运行间隔时间不得少于5分钟。
6. 压缩机内注有本公司认可的最佳的专用冷冻机油，不得随意倒出或添加。
7. 若压缩机附件（如启动器、热保护器等）交货时未安装在压缩机上而是在附件箱内，则必须选用相对应型号的启动器、热保护等。
8. 按低、中、高背压正确匹配压缩机许可的蒸发温度并注意各类压缩机许可的电压、频率范围。
9. 压缩机不能承受高压或真空条件下启动、运行，不能在真空状态下检测绝缘电阻和耐压强度。
10. 凡直接进气和半直接进气的压缩机工艺管和吸气管不能互换，否则压缩机性能将难以保证。
11. 不能用压缩机进行抽真空，不能采用氧气注入制冷系统进行检漏等相关操作，否则容易造成安全事故。
12. 制冷系统设计时应充分考虑系统回油。
13. 压缩机的工作环境不能高于43℃，在最高室温（43℃）时，其连续运转时电流、输入功率不应超过压缩机的极限值。
14. 压缩机出厂后库存期限最好不要超过6个月，如果超过请检查压缩机内干燥氮气是否充足，必要时应补充。

General requirements

1. Compressor should be stored in a dry and drafty place.
2. Compressor should not be tilted or inverted in storage, transportation and installation; collision should be avoided.
3. Rubber plugs should not be pulled out from discharge tube before installation so as to avoid impurity and humidity. During the installation, the rubber plugs of discharge tube should be pulled out at first, then the rubber plugs of process tube, and the rubber plugs of process suction tube at last. The installation should be completed within 10 min after that.
4. The compressor's ground connection should be reliably connected with that of the refrigeration appliance all the time.
5. In order to keep a pressure balance in system, the interval of operation should not be less than 5 min.
6. The charging volume of refrigerant oil has been optimized by our compressor randomly.

7. The accessories (eg. Starter, thermal protection ect.) are not installed into the compressor with delivery, but in the accessory case. Be sure to select the corresponding starter and thermal protection models rightly.
8. Match the proper evaporating temperature according to the low, middle and high back pressure requirements. Pay attention to the admitted ranges of voltage and frequency for the different models.
9. Compressor can not afford a high-voltage or starting/running under vacuum condition. Checking insulation and compressive resistance in vacuum is not allowed.
10. The process or suction tube of direct and semi-direct gas compressor can not be interchanged or it would be difficult to guarantee the performance of compressor.
11. Don't use the compressor as vacuum-pumping. The oxygen injection should be used for leak detection of refrigeration system, or it would be possibly cause accidents.
12. The oil return in system has been fully taken into consideration in design.
13. The temperature of compressor working environment should not be higher than 43℃. The current and input power in its continuous operation should not exceed the limitation of the compressor at the highest room temperature (43℃).
14. The stocking period must be less than 6 months after the date of production. If longer, you have to check whether the filled dry nitrogen is sufficient. Replenishment must be done if necessary.

测试工况 Test Conditions

测试工况 Test Conditions	低背压			中背压	中/高背压	换算单位 Conversion Table
	LBP (ASHRAE)	LBP (ASHRAE)	LBP (CECOMAF)	MBP (ASHRAE)	M/HBP (ASHRAE)	
蒸发温度 Evap.Temp. °C	-23.3	-23.3	-25	-5	7.2	1. kcal/h × 1.163=w
环境温度 Amb.Temp. °C	32.2	43	32	38	38	2. kcal/h × 3.968=Btu/h
过冷温度 Subcooling Temp. °C	32.2	32.2	55	46.1	46.1	3. w × 3.412=Btu/h
冷凝温度 Cond.Temp. °C	54.4	54.4	55	54.4	54.4	4. w × 0.864=kcal/h
吸气温度 Suction Temp. °C	32.2	32.2	32	38	38	5. EER=COP × 3.412
						6. Capacity(50Hz) × 1.16=Capacity(60Hz)

R134a, R290, R404A系列压缩机特殊要求

- 1、R134a, R290, R404A压缩机的敞口时间应尽可能短，不得超过10分钟。
- 2、抽真空泵和充注设备必须专用于R134a, R290, R404A。
- 3、与R134a, R290, R404A不相容的有机物在制冷系统中不得使用。
- 4、R134a, R290, R404A制冷系统应使用于R134a, R290, R404A相适应的干燥过滤器。
- 5、制冷系统应严格控制水份、杂质、石蜡、硅油和氯离子等含量。
- 6、R134a, R290, R404A压缩机内注有本公司认可的专用脂类油，不得随意倒出或添加。

Special requirements for R134a, R290, R404A compressor

1. Don't keep the R134a, R290, R404A compressor connect pipe open too long better, no more than 10 minutes.
2. The vacuum pump and the charging system must only be dedicated to R134a, R290, R404A.
3. The organic substance non-compatible with R134a can't be used in the refrigeration system.
4. R134a, R290, R404A refrigerant system should be used in line with R134a, R290, R404A dry filter.
5. The refrigerant system should strictly control the moisture, impurities, paraffin wax, such as silicone oil and the content of chloride ion.
6. R134a, R290, R404A is MAIDI injection compressor refrigeration approved for lipid oil, are not allowed to randomly pour or add.

R600a系列压缩机特殊要求

- 1、R600a(碳氢)压缩机于制冷器具匹配应用中应遵守并熟练掌握碳氢工质的安全规程，使用相应的工具设备进行操作。
- 2、压缩机运行状况：R600a系列压缩机能在0.22MPa(表压)的平衡力、85%额定电压下启动、运行，在特定条件下压缩机能在电压低至165V，高至242V下启动和运行。
- 3、R600a压缩机内已加注SIKELAN牌压缩机认可的最佳经严格工艺处理过的专用冷冻机油，不得随意倒出或者添加，否则所有的技术保证将无效。
- 4、R600a压缩机必须采用PTC启动器。

Special requirements for R600a compressor

1. R600a (hydrocarbon) compressor and refrigeration equipment should be in compliance with the matching application and mastering of hydrocarbon refrigeration in the safety regulations, the use of appropriate equipment to operate the tools.
2. Compressor Operation: R600a series compressor in the 0.22MPa(gauge) the balance of pressure, 85% rated voltage start running, under certain conditions compressor in the low voltage 165V, 242V to the high start-up and operation.
3. The charging volume of refrigerant oil in R600a compressor has been optimized by our company, which dealt with by strictly technology, do not our or add anymore. Otherwise, all the technical assurance will be invalid.
4. PTC starting relay must be adopted in R600A compressor.

EXECUTIVE STANDARDS

压缩机执行标准

- 1、GB/T5773-2004《容积式制冷剂压缩机性能试验方法》
- 2、GB9098-2008《电冰箱用全封闭式电动机-压缩机》
- 3、GB4706.17-2004《家用和类似用途电器的安全电动机-压缩机特殊要求》
- 4、GB4706.1-1998《家用和类似用途电器的安全第一部分通用要求》
- 5、EN60335-2-34:2002+A1:2004+A1:2005+A2:2009, 同EN60335-1:2002+A11:2004+A12:2006+A2:2006合并使用。
- 6、IEC60335-2-34:2002(4th Edition)+A1:04+A2:08, 同IEC60335-1:2001(4th Edition) (incl. Corrigendum 1:2002)+A1:04+A2:06(incl. Corrigendum 1:2006) 合并使用。

Executive Standards

1. GB/T5773-2004 <The methods of performance test of positive displacement refrigerant>
2. GB9098-2008 <Hermetic motor-compressors of refrigerators>
3. GB4706.17-2004 <Safety of household and similar electrical appliances particular requirement for motor-compressors>
4. GB4706.1-1998 <Safety of Household and Similar Electrical Appliances Part I General Requirement>
5. EN60335-2-34: 2002+A1:2004+A1:2005+A2:2009 used in conjunction with EN60335-1:2002+A11:2004+A12:2006+A2:2006
6. IEC60335-2-34:2002(4th Edition)+A1:04+A2:08 used in conjunction with IEC60335-1:2001(4th Edition)(incl. Corrigendum 1:2002)+A1:04+A2:06(incl. Corrigendum 1:2006)

- 1、应用类型：低背压(LBP)—蒸发温度-35℃~-15℃；中背压(MBP)—蒸发温度-20℃~0℃；高背压(HBP)—蒸发温度-5℃~15℃。
- 2、冷却方式：ST—自然冷却；F1—风扇直径200mm，风速1.5m/s的风冷；F2—风扇直径200mm，风速3m/s的风冷。
- 3、电机类型：RSIR—电阻分相启动；RSCR—电阻启动电容运行；CSIR—电容启动电阻运行；CSR—电容启动电容运行。
- 4、主要参数变化范围：制冷量≥95%；额定电流≤110%；额定功率≤115%；性能系数≥95%。
- 5、以上数据如有变动，恕不另行通知。

- 1—Application: Low Back Pressure(LBP)—Evaporating temperature -35℃~-15℃, Medium Back Pressure(MBP)—Evaporating temperature -20℃~0℃, High Back Pressure—Evaporating temperature -5℃~15℃.
- 2—Cooling type: ST—static cooling, F1—fan diameter 200mm and 1.5m/s air cooling of wind velocity, F2—fan diameter 200mm and 3m/s air cooling of wind velocity.
- 3—Motor type: RSIR, RSCR, CSIR, CSR.
- 4—Tolerance of main performance data: cooling capacity≥95%, rated current≤110%, rated powers≤115%, COP≥95%.
- 5—All data is subject to change without notice.